

CAPACITIVE SENSORS

HIGH PRECISION NON-CONTACT SENSORS

Position
Displacement
High Speed
High Resolution
Customizable Solutions
Off the Shelf

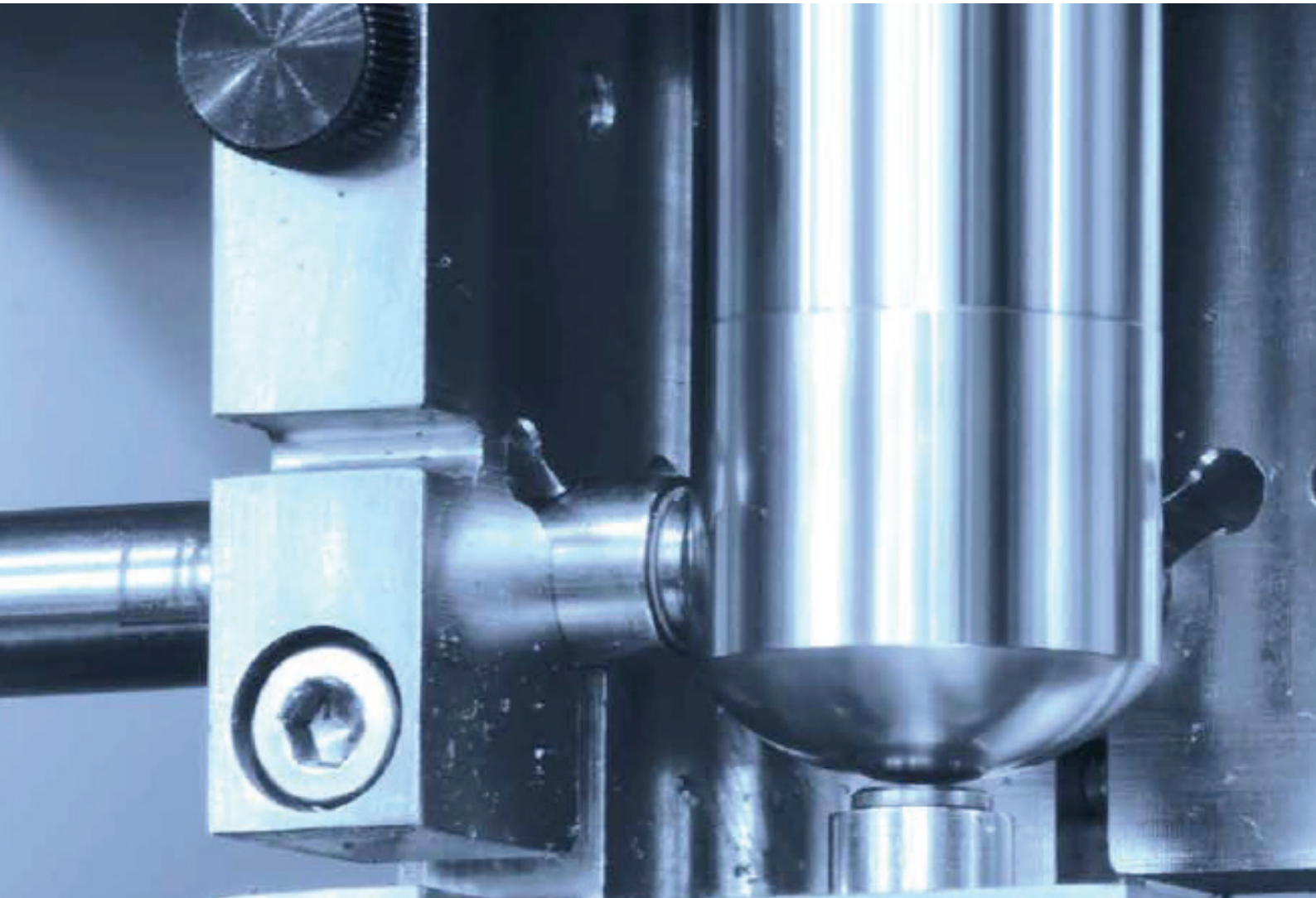

CAPACITIVE SENSORS

Capacitive Sensor Diagram

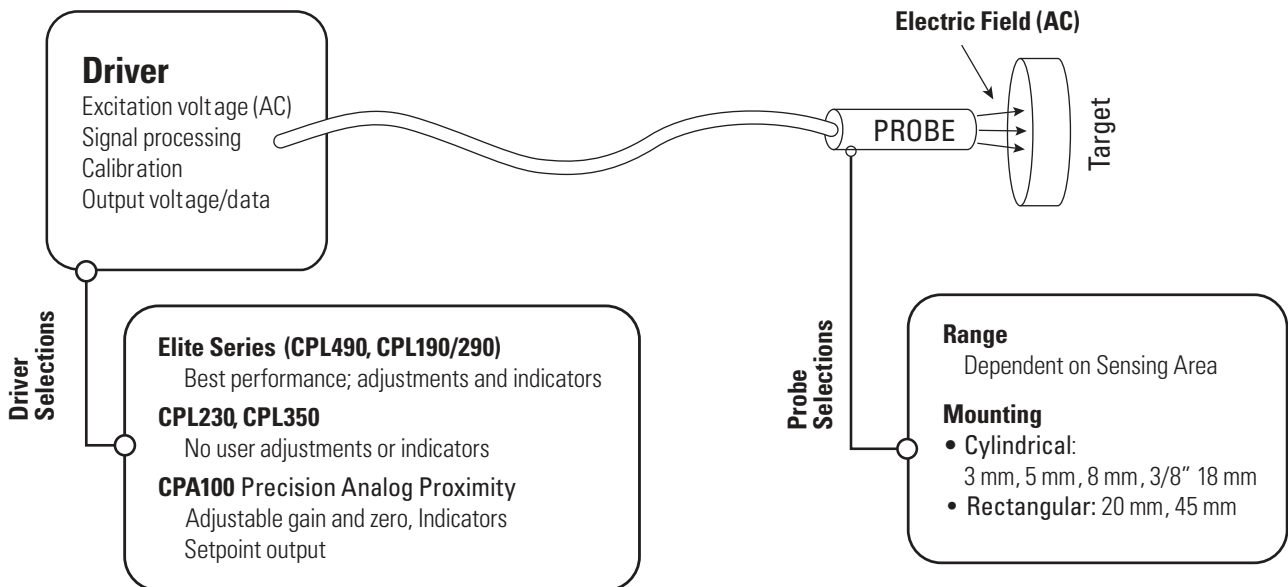

Custom Sensor Design

We are glad to work with you on custom probes and electronics for your specific application. Over half of our orders are customized, this includes:

- Custom Probe Shapes And Designs
- Custom Cable Lengths And Connectors
- Vacuum Compatible Probes
- Custom Ranges
- Custom Electronics



lionprecision.com

Our Lion Precision Technical Library provides a high level of technical detail about all of our products and technologies including all manuals and drawings of the probes.

Our Capacitive Sensing Theory of Operation TechNote is viewed thousands of times a month.

Product Selection Guide

Selecting the Right Technology

ELITE SERIES



Product Selection Guide		CPL591/592	CPL490	CPL190/290	CPL230	CPL350	CPA100
STANDARD TECHNICAL SPECIFICATIONS	Typical Resolution* (% F.S. rms) @ 15 kHz	0.004%	0.0007%	0.003%	0.004%	0.004%	0.03% @ Midrange
	Nonlinearity*	0.1%	0.2%	0.2%	0.5%	0.2%	0.2%
	Dual Range (Sensitivity)	✓		CPL290			
	User Adjustments	✓	✓	✓			✓
	Adjustable Gain						✓
	Adjustable Offset	✓	✓	✓			✓
	Range Indicator	✓	✓	✓			✓
	Setpoint/ Switched Output						✓
	Channels Per Package	1 - 8	1 - 3	1 - 8	1 - 6	1	1
	Selectable Bandwidth (Internal Dip-Switch)	0.1, 1, 10, 15 kHz	1, 10, 15, 50 kHz	0.1, 1, 10, 15 kHz	0.1, 1, 10, 15 kHz	0.1, 1, 10, 15 kHz	15 kHz
	Maximum Bandwidth	15 kHz	50 kHz	15 kHz	15 kHz	15 kHz	15 kHz
	Customization Available	✓	✓	✓	✓	✓	✓
	Digital Output	✓					

* Typical Specifications dependent on probe and range

*Specifications listed on the following page are for probes with standard 2 meter cables.

Listed specifications do not apply when customization is included. Performance of customized product will depend on specific options.

Probe Vacuum Compatibility (to 10⁻⁶ Torr)

Probe High-Vacuum Compatibility (to 10⁻¹² Torr)

Options requiring custom calibration and deviation from listed specifications:

- Custom Ranges
- Nonflat or Undersized Target Shape
- Custom Cable Length
- Probe Extension Cables (2 m, 3m, 4 m; Probes calibrated with extension cables must be used with them)

CAPACITIVE DRIVER

CPL590

Capacitive Driver

- Digital Outputs
- USB, SPI and EtherCAT
- Small 2U Size
- Up to 4 Selectable Ranges on 1 Probe
- Best Linearity
- Higher Stability
- Digital Adjustment

Specifications

Resolution ¹ :	0.0005% @ 100 Hz
	0.003% @ 15 kHz
Selectable Bandwidth:	100Hz, 1, 10, 15kHz
Linearity:	<0.1% F.S. typical
Probe Drift:	0.04% F.S./°C
Operating Temp:	4-50°C
Output:	±10V, 0Ω 10mA max
Rear-Panel:	SPI, EtherCAT

1. Dependent on probe, range, and bandwidth. See next page for details.

2. Dependent on probe and range. See next page for details.

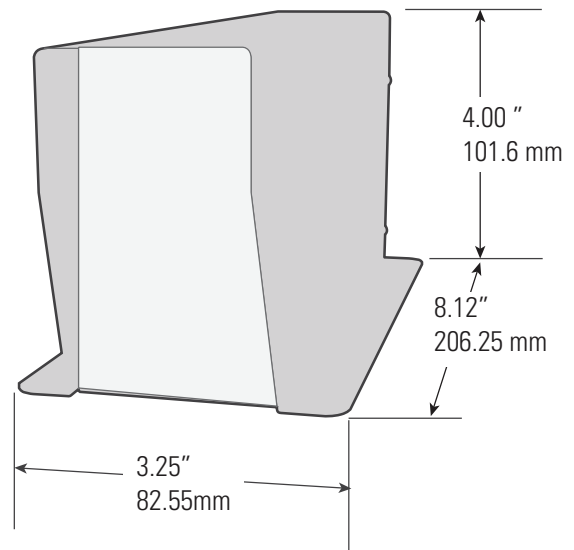

Export License

Requires and export license.

Selecting the Right Technology

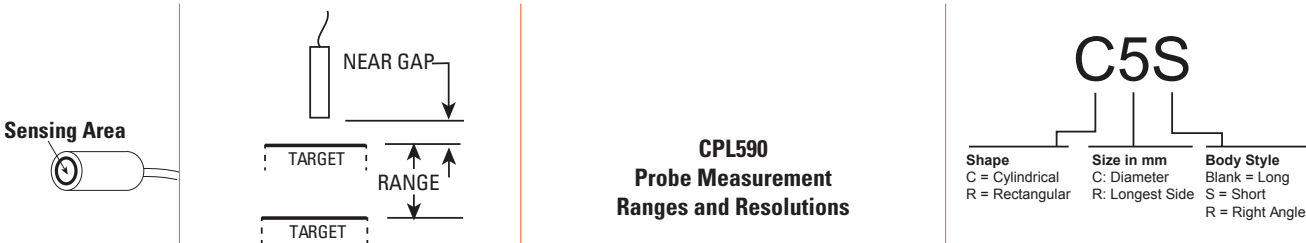

Sensing Area Diameter mm	Measurement Range			Resolution ¹ @ Bandwidth			Available Body Sizes		
	Range Type	Range μ mils	Near Gap μ mils	1 kHz nm μ in	10 kHz nm μ in	15 kHz nm μ in	Linearity	Models	Body Sizes
0.5	Fine	10 0.4	20 0.8	0.14 0.006	0.56 0.022	0.70 0.028	1.0	C3S C3R C5S C5R C5	
	Standard	50 2.0	50 2.0	0.70 0.028	4.2 0.17	5.6 0.22	0.50		
	Extended	80 3.0	60 2.4	1.4 0.056	7.0 0.28	—	0.50		
0.8	Fine	25 1.0	75 3.0	0.70 0.028	1.7 0.070	2.1 0.084	0.50	C3S C3R	
	Standard	100 4.0	100 4.0	1.4 0.056	4.9 0.20	7.0 0.28	0.50		
2.0	Ultrafine	10 0.4	20 0.8	0.11 0.004	0.21 0.008	0.35 0.014	1.0	C5S C5R C5 C8S C8R C8	
	Fine	50 2.0	75 3.0	0.42 0.017	0.84 0.034	1.4 0.056	0.30		
	Standard	250 10.0	125 5.0	0.56 0.060	5.6 0.22	7.0 0.28	0.30		
	Extended	500 20.0	125 5.0	4.2 0.17	11 0.44	14 0.56	0.30		
3.2	Fine	50 2.0	125 5.0	0.56 0.022	1.4 0.056	2.2 0.073	0.30	C8S C8R C8	
	Standard	500 20.0	250 10	4.2 0.17	8.4 0.37	14 0.56	0.30		
	Extended	1250 50.0	250 10	21 0.84	28 1.1	42 1.7	0.30		
5.6	Fine	50 2.0	225 9.0	0.56 0.022	1.1 0.44	1.8 0.072	0.30	C9.5S C9.5R C9.5 R20	
	Standard	500 20.0	500 20	4.2 0.17	9.8 0.39	14 0.56	0.30		
	Extended	2000 80.0	250 10	14 0.56	28 1.1	42 1.7	0.30		
13	Fine	2000 80	2000 80	42 1.7	49 4.2	56 2.2	0.50	C18	
	Standard	3200 125	2000 80	56 2.2	70 2.8	84 3.4	0.50		
	Extended	5000 200	3000 120	140 5.6	180 7.3	210 8.4	0.50		
19	Standard	2500 100	5000 200	100 3.9	100 5.0	140 5.6	0.50	R45	
	Extended	6000 250	3000 120	170 6.7	100 9.0	250 10	1.0		
21	Standard	8000 300	5000 200	140 5.6	180 7.3	210 8.4	0.50	C25	
	Extended	12500 500	5000 200	250 10	320 13	350 14	0.50		

Resolution values are RMS. Peak-to-peak values are typically 8-10 times greater than the RMS values.
 In high EMI conditions (10 V/m) output DC level may shift and noise may rise to 0.2 VRMS (1.3% resolution).

CAPACITIVE DRIVER

CPL490

Elite Series

- Highest resolution
- Widest bandwidth (50 kHz)
- Five-element range indicator
- Zero adjust
- Front-panel BNC analog output
- Differential output to National Instruments 68-pin connector
- Uses 2nd Generation Probes

Specifications

Resolution ¹ :	0.0004% @ 1 kHz
	0.0007% @ 15 kHz
	0.002% @ 50 kHz
Selectable Bandwidth:	1, 10, 15, 50 kHz
Linearity ² :	<0.2% F.S. typical
Max Drift:	0.02-0.04% F.S./°C
Operating Temp:	15-40°C
Front-Panel BNC:	±10V, 0Ω 10mA max
Rear-Panel National Inst:	±10V, 0Ω Differential
Multiple Channels:	Up to 3 per enclosure (Contact Lion Precision for more than 3)

1. Dependent on probe, range, and bandwidth. See next page for details.

2. Dependent on probe and range. See next page for details.

Listed [specifications](#) assume a two meter probe cable: Flat measurement area diameter at least 1.3 times larger than the Sensing Area with no customizations.

The CPL490 uses 2nd Generation probes.

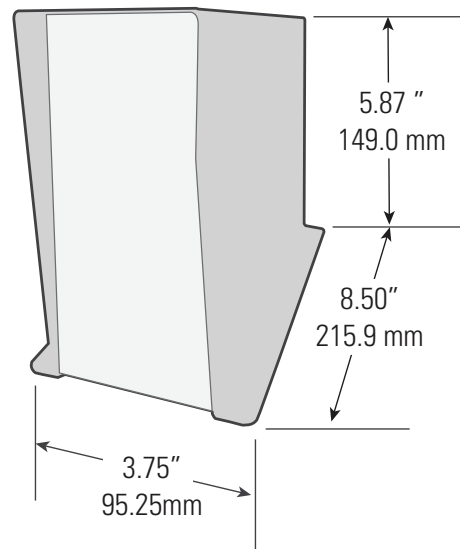

Export License

Requires and export license.

Second Generation Probes

- The CPL490 uses 2nd Generation Capacitive Probes which include electronics in the probe housing.
- The probes are mounted by the 8mm diameter probe body extending from the larger housing.
- Two models are available differing only in the sensing area diameter and associated measurement ranges.

2G-C8-0.5: 0.5 mm sensing area
 2G-C8-1.2: 1.2 mm sensing area

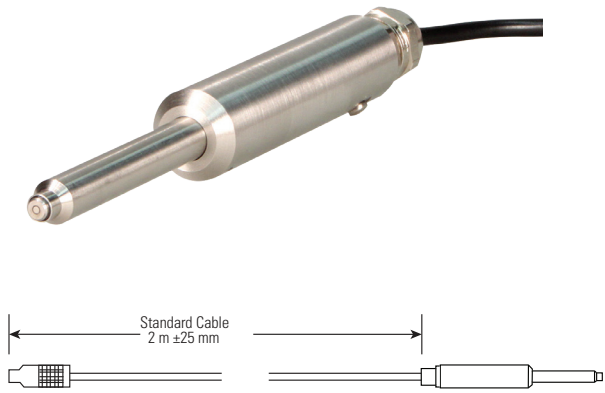
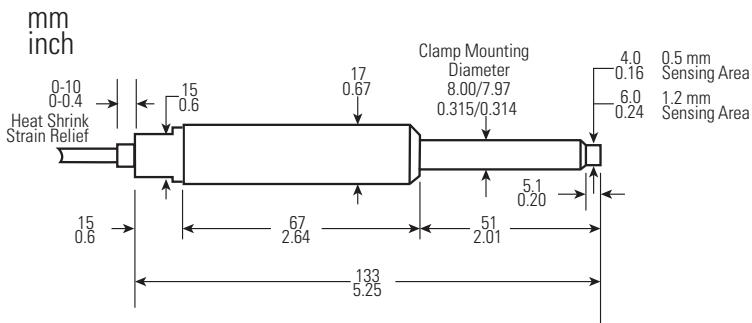

Sensing Area

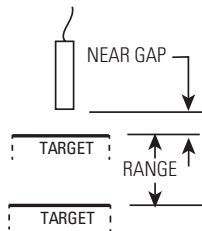
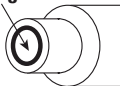

CPL490 Probe Measuremen Ranges and Resolutions

Sensing Area Diameter mm (Probe Model)	Range Type	Range	Near Gap	1 kHz	10 kHz	15 kHz	50 kHz	Probe Max. Drift % FS/°C
		µm mils	µm mils	nm µin	nm µin	nm µin	nm µin	
0.5 (2G-C8-0.5)	Fine	10 0.4	20 0.8	0.05 0.002	0.07 0.003	0.09 0.004	0.26 0.010	0.04
	Standard	50 2.0	25 1.0	0.17 0.007	0.27 0.011	0.35 0.014	1.0 0.040	0.02
	Extended	100 4.0	50 2.0	0.38 0.015	0.80 0.31	1.0 0.039	3.3 0.14	0.03
1.2 (2g-C8-1.2)	Fine	50 2.0	25 1.0	0.15 0.006	0.20 0.008	0.22 0.009	0.63 0.25	0.02
	Standard	100 4.0	50 2.0	0.33 0.013	0.40 0.016	0.52 0.021	1.7 0.065	0.02
	Ultrafine	200 8.0	100 4.0	0.68 0.027	1.0 0.040	1.3 0.050	3.8 0.15	0.02

Range is determined by the sensing area diameter. The larger the diameter, the larger the range. Flat target surface must be 1.3 times larger than the sensing area diameter.

CAPACITIVE DRIVER

CPL190/CPL290

Elite Series

- High resolution five-element range indication
- Coarse/Fine zero adjust with disable
- Front-panel BNC analog output
- Differential output to National Instruments 68-pin connector

Specifications

Resolution ¹ :	0.0005% @ 100 kHz
	0.003% @ 15 kHz
Selectable Bandwidth:	100 Hz, 1, 10, 15 kHz
Linearity ² :	<0.2% F.S. typical
Max Drift:	0.04% F.S./°C
Operating Temp:	-50°C
Front-Panel BNC:	±10V, 0Ω 10mA max
Rear-Panel National Inst:	±10V, 0Ω Differential

1. Dependent on probe, range, and bandwidth. See next page for details.
2. Dependent on probe and range. See next page for details.

Listed [specifications](#) assume a two meter probe cable; Flat measurement area diameter at least 1.3 times larger than the Sensing Area with no customizations.

Different probe body styles/sizes are available for each Sensing area.



Export License

Requires and export license.

CPL190/CPL290

Probes and Ranges

Sensing Area

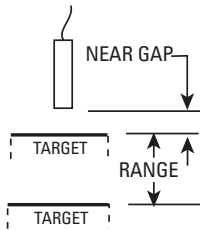

CPL190/290

Probe Measurement Ranges and Resolutions

C5S

Shape Size in mm Body Style
 C = Cylindrical C: Diameter Blank = Long
 R = Rectangular R: Longest Side S = Short
 R = Right Angle

Sensing Area Diameter mm	Measurement Range			Resolution ¹ @ Bandwidth					Available Body Sizes	
	Range Type	Range μm mils	Near Gap μm mils	100 Hz nm μin	1 kHz nm μin	10 kHz nm μin	15 kHz nm μin	Linearity % F.S.	Models	Body Sizes
0.5	Fine	10 0.4	20 0.8	0.06 0.003	0.14 0.006	0.40 0.016	0.50 0.020	0.25	C3S C3R C5S C5R C5	
	Standard	50 2.0	50 2.0	0.30 0.012	0.50 0.020	3.0 0.12	4.0 0.16	0.25		
	Extended	80 3.0	60 2.4	0.50 0.02	1.0 0.040	5.0 0.20	–	0.25		
0.8	Fine	25 1.0	75 3.0	0.20 0.008	0.50 0.020	1.2 0.050	1.5 0.060	0.15	C3S C3R C5S C5R C5	
	Standard	100 4.0	100 4.0	0.50 0.020	1.0 0.040	3.5 0.14	5.0 0.20	0.15		
2.0	Ultrafine	10 0.4	20 0.8	0.05 0.002	0.08 0.003	0.15 0.006	0.25 0.010	0.15	C5S C5R C5 C8S C8R C8	
	Fine	50 2.0	75 3.0	0.20 0.008	0.30 0.012	0.60 0.024	1.0 0.040	0.15		
	Standard	250 10.0	125 5.0	0.8 0.032	1.0 0.040	4.0 0.16	5.0 0.20	0.10		
	Extended	500 20.0	125 5.0	1.5 0.060	3.0 0.12	8.0 0.32	10 0.40	0.15		
3.2	Fine	50 2.0	125 5.0	0.25 0.010	0.4 0.016	1.0 0.042	1.6 0.048	0.20	C8S C8R C8	
	Standard	500 20.0	250 10	2.0 0.08	3.0 0.12	6.0 0.24	10 0.40	0.15		
	Extended	1250 50.0	250 10	10 0.40	15 0.60	20 0.80	30 1.2	0.20		
5.6	Fine	50 2.0	225 9.0	0.3 0.012	0.4 0.016	0.8 0.032	1.3 0.052	0.20	C9.5S C9.5R C9.5 R20	
	Standard	500 20.0	500 20	2.5 0.100	3.0 0.12	7.0 0.28	10 0.40	0.15		
	Extended	2000 80.0	250 10	7.0 0.28	10 0.40	20 0.80	30 1.2	0.20		
13	Fine	2000 80	2000 80	20 0.80	30 1.2	35 1.4	40 1.6	0.50	C18	
	Standard	3200 125	2000 80	30 1.2	40 1.6	50 2.0	60 2.4	0.50		
	Extended	5000 200	3000 120	75 3.0	100 4.0	130 5.2	150 6.0	0.50		
19	Standard	2500 100	5000 200	50 2.0	70 2.8	90 3.6	100 4.0	0.30	R45	
	Extended	6000 250	3000 120	90 3.6	120 4.8	160 6.4	180 7.2	1.0		
21	Standard	8000 300	5000 200	75 3.0	100 4.0	130 5.2	150 6.0	0.50	C25	
	Extended	12500 500	5000 200	130 5.2	180 7.2	230 9.2	250 10	0.50		

Resolution values are RMS. Peak-to-peak values are typically 8-10 times greater than the RMS values.
 In high EMI conditions (10 V/m) output DC level may shift and noise may rise to 0.2 VRMS (1% resolution).

CAPACITIVE DRIVER

CPL230

Compact, Multi-Channel Driver

- High resolution five-element range indication
- Separate power and signal connectors
- OEM and embedded application
- Small Size, high-density package
- No user adjustments
- $\pm 5V$ single-ended output, $\pm 10V$ differential output



CPL350

Compact, Single-Channel Driver

- OEM and embedded applications
- $\pm 10V$ single-ended
- BNC output
- $\pm 10V$ differential D-Sub output
- No user adjustments
- Small size
- High-density package



Specifications

Resolution ¹ :	0.0007% @ 100 kHz
	0.004% @ 15 kHz
Selectable Bandwidth:	100 Hz, 1, 10, 15 kHz
Linearity ² :	<0.5% F.S. typical
Probe Drift:	0.04% F.S./°C
Operating Temp:	4-50°C
Output:	$\pm 10 V$, Differential
	$\pm 5 V$, Single-Ended
Input Power ³ :	$\pm 15 VDC$, 500 mA max

1. Dependent on probe, range, and bandwidth. See next page for details.

2. Dependent on probe and range. See next page for details.

3. External power supply included. See next page for details.

Listed [specifications](#) assume a two meter probe cable; Flat measurement area diameter at least 1.3 times larger than the Sensing Area with no customizations.

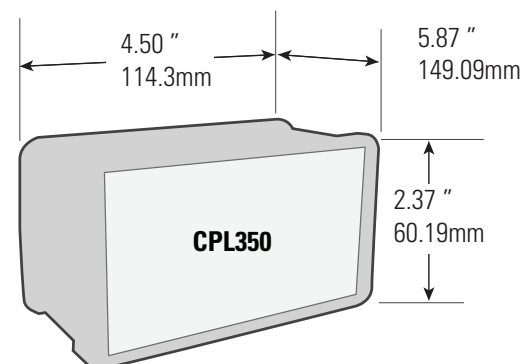
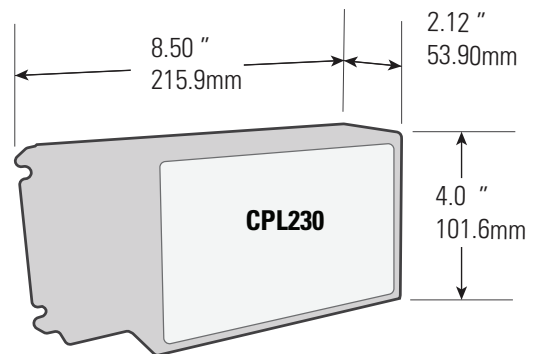

Export License

Requires and export license.

CPL230/350

Probes and Ranges

Sensing Area

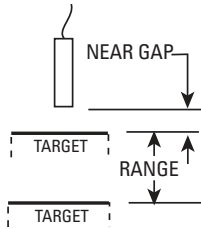
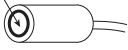

CPL230/350

Probe Measurement Ranges and Resolutions

C5S

Shape
C = Cylindrical
R = Rectangular

Size in mm
C: Diameter
R: Longest Side

Body Style
Blank = Long
S = Short
R = Right Angle

Sensing Area Diameter mm	Measurement Range			Resolution ¹ @ Bandwidth				Linearity	Available Body Sizes	
	Range Type	Range μm mils	Near Gap μm mils	100 Hz nm μin	1 kHz nm μin	10 kHz nm μin	15 kHz nm μin		Models	Body Sizes
0.5	Fine	10 0.4	20 0.8	0.08 0.003	0.14 0.006	0.56 0.022	0.70 0.028	1.0	C3S C3R C5S C5R C5	
	Standard	50 2.0	50 2.0	0.42 0.017	0.70 0.028	4.2 0.17	5.6 0.22	0.50		
	Extended	80 3.0	60 2.4	0.70 0.028	1.4 0.056	7.0 0.28	—	0.50		
0.8	Fine	25 1.0	75 3.0	0.28 0.011	0.70 0.028	1.7 0.070	2.1 0.084	0.50	C3S C3R C5S C5R C5	
	Standard	100 4.0	100 4.0	0.70 0.030	1.4 0.056	4.9 0.20	7.0 0.28	0.50		
2.0	Ultrafine	10 0.4	20 0.8	0.07 0.003	0.11 0.004	0.21 0.008	0.35 0.014	1.0	C5S C5R C5 C8S C8R C8	
	Fine	50 2.0	75 3.0	0.28 0.011	0.42 0.017	0.84 0.034	1.4 0.056	0.30		
	Standard	250 10.0	125 5.0	1.1 0.04	0.56 0.060	5.6 0.22	7.0 0.28	0.30		
	Extended	500 20.0	125 5.0	2.1 0.084	4.2 0.17	11 0.44	14 0.56	0.30		
3.2	Fine	50 2.0	125 5.0	0.35 0.014	0.56 0.022	1.4 0.056	2.2 0.073	0.30	C8S C8R C8	
	Standard	500 20.0	250 10	2.8 0.11	4.2 0.17	8.4 0.37	14 0.56	0.30		
	Extended	1250 50.0	250 10	14 0.56	21 0.84	28 1.1	42 1.7	0.30		
5.6	Fine	50 2.0	225 9.0	0.42 0.017	0.56 0.022	1.1 0.44	1.8 0.072	0.30	C9.5S C9.5R C9.5 R20	
	Standard	500 20.0	500 20	3.5 0.14	4.2 0.17	9.8 0.39	14 0.56	0.30		
	Extended	2000 80.0	250 10	9.8 0.39	14 0.56	28 0.11	42 1.7	0.30		
13	Fine	2000 80	2000 80	28 1.1	42 1.7	49 2.0	56 2.2	0.50	C18	
	Standard	3200 125	2000 80	42 1.7	56 2.2	70 2.8	84 3.4	0.50		
	Extended	5000 200	3000 120	100 4.0	140 5.6	180 7.3	210 8.4	0.50		
19	Standard	2500 100	5000 200	70 2.8	100 3.9	100 5.0	140 5.6	0.50	R45	
	Extended	6000 250	3000 120	130 5.2	170 6.7	100 9.0	250 10	1.0		
21	Standard	8000 300	5000 200	100 4.0	140 5.6	180 7.3	210 8.4	0.50	C25	
	Extended	12500 500	5000 200	180 7.3	250 10	320 13	350 14	0.50		

Resolution values are RMS. Peak-to-peak values are typically 8-10 times greater than the RMS values.
In high EMI conditions (10 V/m) output DC level may shift and noise may rise to 0.2 VRMS (1.3% resolution).

CAPACITIVE DRIVER

CPA100

Precision Analog Proximity Switch

- Lower Cost
- 0-10 V nonlinear analog output
- Setpoint/Switched output
- Adjustable gain and zero
- Five-element range indicator
- Remote gain and zero adjustment connections
- DIN rail case
- Multiple channel sync

Specifications

Resolution ¹ :	CPA100: 0.03% RMS@ 15 kHz
	CPA 100e: 0.3µm RMS or higher @ 15 kHz
Bandwidth:	15 kHz
Linearity:	Nonlinear
Max Drift:	Driver: 0.2% F.S./°C
	Probe: 0.05% F.S./°C
Analog Output:	0-10V, 0Ω, 15mA max.
Setpoint:	Fixed at 5 V (mid-range)
Setpoint Output:	Solid state switch closure
On state:	2.5Ω, 100mA max
Off state leakage:	10µA max
Operating Temp:	4-50°C
Onput Power ² :	15-24 VDC, 2.5W

1. Typical at midpoint. Dependent on probe, range, and bandwidth. See next page for details.

2. External power supply not included – available as accessory (p.3)

Listed [specifications](#) assume a two meter probe cable; Flat measurement area diameter at least 1.3 times larger than the Sensing Area with no customizations.

Different probe body styles/sizes are available for each Sensing area.

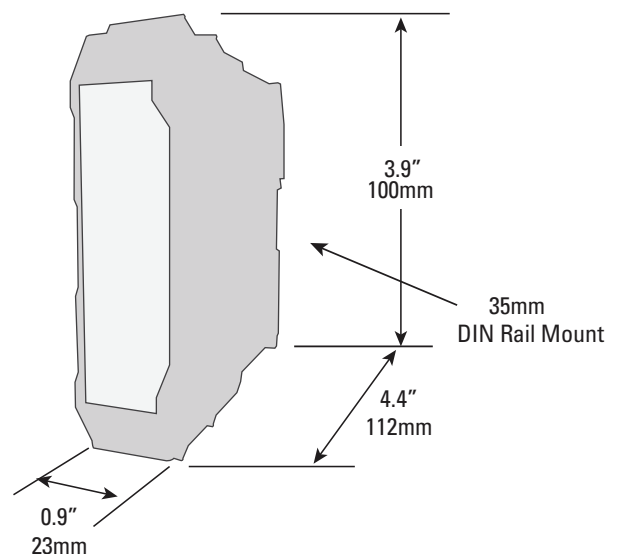
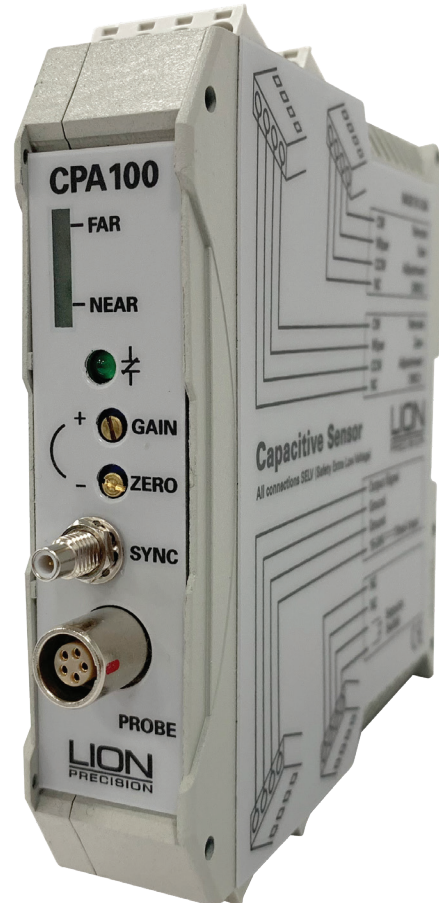

Export License

Requires and export license.

CPA100

Probes and Ranges

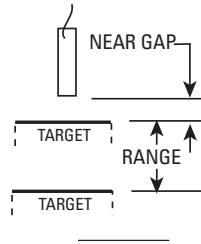
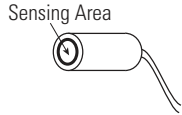

CPA100 Probe Measurement Ranges and Resolutions

C5S

Shape: C = Cylindrical, R = Rectangular
 Size in mm: C: Diameter, R: Longest Side
 Body Style: Blank = Long, S = Short, R = Right Angle

Sensing Area Diameter mm	Measurement Range			Midpoint Resolution ¹ @ 15 kHz		Available Body Sizes		
	Range Type	Range μm mils	Near Gap μm mils	CPA100 μm μin	CPA100e μm μin	Models	Body Sizes	
0.5	Standard	50 2.0	50 2.0	55 2.2	400 16	C3S C3R	C5S C5R C5	
	Extended	80 3.0	60 2.4	100 4.0	400 16			
0.8	Standard	100 4.0	100 4.0	55 2.2	400 16	C3S C3R	C5S C5R C5	
2.0	Standard	250 10.0	125 5.0	40 1.6	400 16	C5S C5R C5	C8S C8R C8	
	Extended	500 20.0	125 5.0	55 2.2	400 16			
3.2	Standard	500 20.0	250 10	85 3.4	400 16	C8S C8R C8		
	Extended	1250 50.0	250 10	130 5.2	400 16			
5.6	Standard	500 20.0	500 20	140 5.5	400 16	C9.5S C9.5R C9.5		
	Extended	2000 80.0	250 10	170 6.7	800 32			
13	Standard	3200 125	2000 80	1000 40	1000 40	C18		
	Extended	5000 200	3000 120	1600 63	1600 63			
19	Standard	2500 100	5000 200	800 32	800 32	R45		
	Extended	6000 250	3000 120	1100 44	1100 44			
21	Standard	8000 300	5000 200	1200 47	1200 47	C25		
	Extended	12500 500	5000 200	1600 63	1600 63			

The CPA100 does not require an export license.

CAPACITIVE PROBES

Probe Model Numbers

- Probe model numbers are a combination of the Body Model number and Sensing Area Diameter in mm (e.g. C5S-08 or R45-19).
- Cad Files available at www.lionprecision.com/technical-library

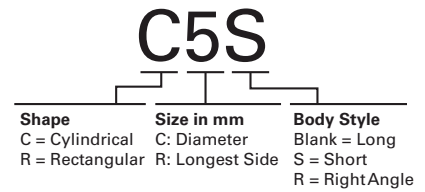

Size/Shape	Body Model	Mechanical	Sensing Area 	Sensing Area Diameter (mm)	Measurement Ranges (by Driver Model)	
					CPL190, CPL290 CPL230, CPL350 µm mils	CPA100 µm mils
3mm Cylindrical	C3S			0.5	10, 50, 80 0.4, 2.0, 3.0	50, 80 2.0, 3.0
				0.8	25, 100 1.0, 4.0	100 4.0
	C3R			0.5	10, 50, 80 0.4, 2.0, 3.0	50, 80 2.0, 3.0
				0.8	25, 100 1.0, 4.0	100 4.0
5mm Cylindrical	C5			0.5	10, 50, 80 0.4, 2.0, 3.0	50, 80 2.0, 3.0
				0.8	25, 100 1.0, 4.0	100 4.0
				2.0	10, 50, 250, 500 0.4, 2.0, 10.0, 20.0	250, 500 10.0, 20.0
	C5S			0.5	10, 50, 80 0.4, 2.0, 3.0	50, 80 2.0, 3.0
				0.8	25, 100 1.0, 4.0	100 4.0
				2.0	10, 50, 250, 500 0.4, 2.0, 10.0, 20.0	250, 500 10.0, 20.0
C5R			0.5	10, 50, 80 0.4, 2.0, 3.0	50, 80 2.0, 3.0	
			0.8	25, 100 1.0, 4.0	100 4.0	
			2.0	10, 50, 250, 500 0.4, 2.0, 10.0, 20.0	250, 500 10.0, 20.0	
20mm Rectangle	R20			5.6	50, 500, 2000 2.0, 20.0, 80.0	200, 2000 20.0, 80.0

Standard cable length: 2 meters. Operating and storage temperature range: 4-50°C. Available as vacuum compatible.

Probes are not damaged by contact with the sensing tip.

Range is determined by the probe Sensing Area diameter – the larger the diameter, the larger the range.

To hold [specifications](#), flat target surface diameter must be 1.3 times larger than the sensing area diameter.

Measurement Ranges and other performance [specifications](#) are dependent on the selected driver model.

Size/Shape	Body Model	Mechanical	Sensing Area Diameter (mm)	Measurement Ranges (by Driver Model)		
				CPL190, CPL290 CPL230, CPL350 µm mils	CPA100 µm mils	
8mm Cylindrical	C8			2.0	10, 50, 250, 500 0.4, 2.0, 10.0, 20.0	250, 500 10.0, 20.0
				3.2	50, 500, 1250 2.0, 20.0, 50.0	500, 1250 20.0, 50.0
	C8S			2.0	10, 50, 250, 500 0.4, 2.0, 10.0, 20.0	250, 500 10.0, 20.0
				3.2	50, 500, 1250 2.0, 20.0, 50.0	500, 1250 20.0, 50.0
	C8R			2.0	10, 50, 250, 500 0.4, 2.0, 10.0, 20.0	250, 500 10.0, 20.0
				3.2	50, 500, 1250 2.0, 20.0, 50.0	500, 1250 20.0, 50.0
9.5mm (3/8") Cylindrical	C9.5			5.6	50, 500, 2000 2.0, 20.0, 80.0	500, 2000 20.0, 80.0
	C9.5S			5.6	50, 500, 2000 2.0, 20.0, 80.0	500, 2000 20.0, 80.0
	C9.5R			5.6	50, 500, 2000 2.0, 20.0, 80.0	500, 2000 20.0, 80.0
18mm Cylindrical	C18			13	2000, 3200, 5000 80, 125, 2000	3200, 5000 125, 200
25mm Cylindrical	C25			21	8000, 12500 300, 500	8000, 12500 300, 500
45mm (1.75") Cylindrical	R45			19	2500, 6000 100, 250	2500, 6000 100, 250

CAPACITIVE SENSORS

Typical Applications

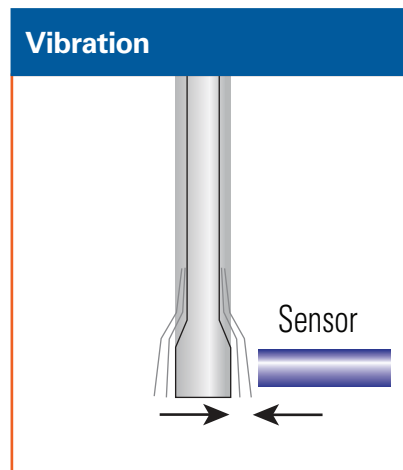
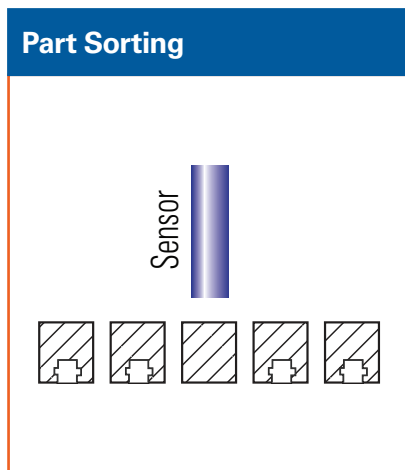
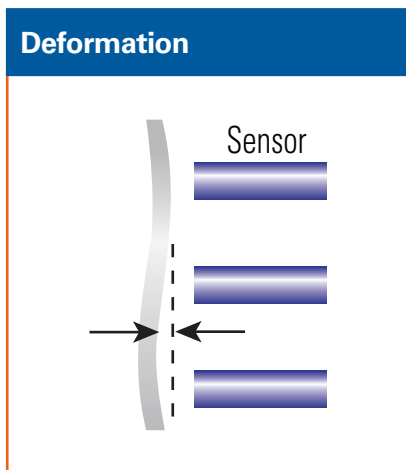
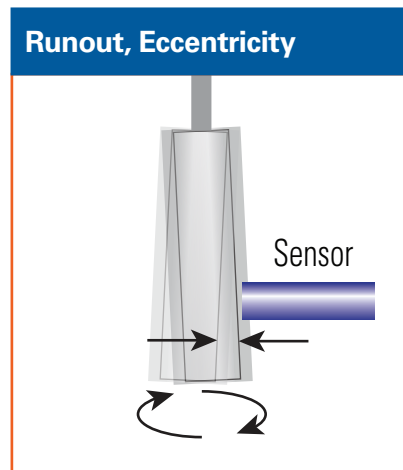
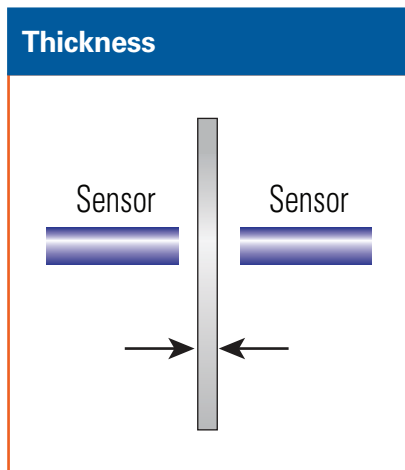
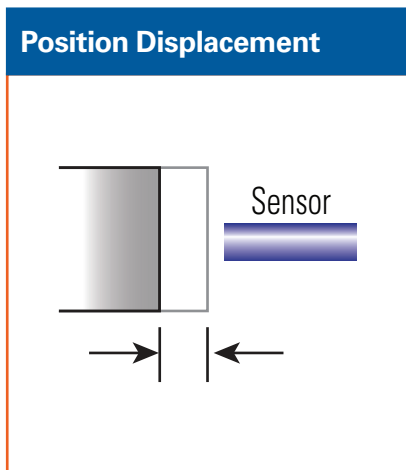

COMMITMENT TO SERVICE

Lion Precision's commitment to service is unsurpassed in the industry. We partner with our customers to ensure their success by providing optimized sensing solutions. Contact us today and let us solve your difficult measurement problems.