

# LION

---

# PRECISION



## USER'S GUIDE

for the

# LRD2100 and LRD2100C

### Capacitive Label Sensor

## Warnings

Sensor body is connected to Ground.

Sensors must not be attached to voltages in excess of 30VRMS or 60VDC

All power must be off when installing the sensor.

Use of the equipment in any other manner may impair the safety and EMI protections of the equipment.

## LRD2100 Wiring

Wire Color	Connection	Notes
Red	Vin (11-28V $\overline{=}$ )	50mA max.
Black	Ground	Connected to sensor body
Green	NPN Output	150mA max.
Blue	PNP Output	150mA max.
Brown	Output Polarity (light/dark switching)	+V or Ground See detail on back

Warning: Brown wire must be connected to +V or Ground for reliable operation.

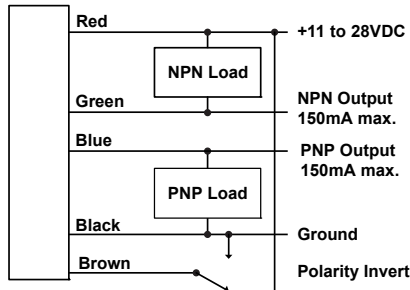

## LRD2100C Wiring

Wire Color	Connection	Notes
1 (Brown)	Vin (11-28V $\overline{=}$ )	50mA max.
2 (White)	Ground	Connected to sensor body
3 (Blue)	NPN Output	150mA max.
4 (Black)	PNP Output	150mA max.
5 (Gray)	Output Polarity (light/dark switching)	+V or Ground See detail on back

Warning: Gray wire (pin 5) must be connected to +V or Ground for reliable operation.

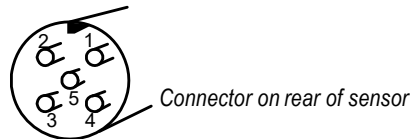
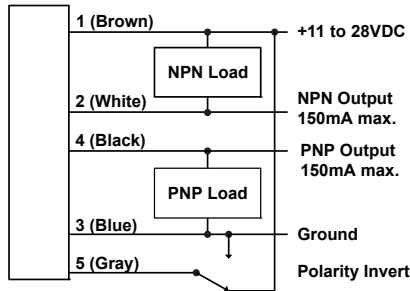

See [www.labelsensors.com](http://www.labelsensors.com) for helpful information.

## Adjusting the LRD2100

The adjustments on the LRD2100 have a maximum of four (4) turns. If they are turned beyond the end points, the adjustments will continue to turn without damaging the sensor, but no further adjustment will occur.

## Adjustments When First Installed On A Machine

1. Remove all material from sensor.
2. Set GAIN ADJUST to maximum by turning at least four (4) turns clockwise.
3. Set ZERO ADJUST

Turn the Zero adjustment to where the Zero light changes between On and Off. It's not important whether it is On or Off when completed, as long as it is close to where it changes.

4. It is recommended that you place a round black label (several are included with the sensor) over the Zero adjustment to prevent unnecessary adjustment in the future.

5. Set GAIN ADJUST to midpoint by turning two (2) turns counterclockwise

This setup will work with most labels and not require readjustment. The Zero may have to be adjusted again if the baseplate or spacer is ever replaced or removed.

## Adjustments When Label Stock Is Changed

**Usually None.** The basic setting above (Gain at center of its range) will work for most labels. Very small labels may require an increase in Gain.

If, and ONLY if, the new labels aren't being detected correctly, use this procedure:

1. Re-Set the Gain to center of its range
  - a. Turn the Gain adjustment at least 4 full turns clockwise
  - b. Turn the Gain adjustment 2 turns counterclockwise

Run and see if the sensor works correctly. If it does, the Gain had been adjusted and needed to be re-centered. If it still does not work correctly, then use this procedure to fine-tune the Gain setting

1. Set Gain to Minimum by turning it 4 turns counterclockwise
2. Move labels through the sensor and increase GAIN (turn clockwise) until the OUTPUT light ("EDGE" on older models) just begins to flash. If possible, it may be easier to create some slack in the web and just move one gap back-and-forth through the sensor while adjusting.
3. Turn the Gain adjustment another half-turn clockwise.
4. If the sensor still doesn't detect labels reliably, you may have label materials that require an LRD6300 or LRD8200.

## Lights During Operation

The OUTPUT light (EDGE on older models) indicates the sensor output. It will be in one state (on or off) during the label and the other state during the gap depending on the direction of the label movement and the connection of the Polarity Invert wire (see next page for details).

The Zero light is for first-time setup only and is meaningless during operation.

## Notes

1. For best results, web should ride against sensor baseplate, not "float" in the gap.

# Output and Mechanical Detail

Light/Dark switching is affected by the direction of label movement and the Output Polarity connection. Output descriptions below are for web direction indicated in the illustration and are reversed for web movement in the other direction.

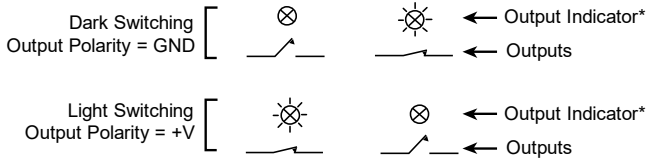
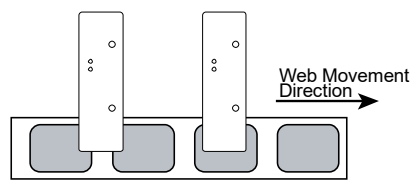

\*Some models label this indicator as "Edge"

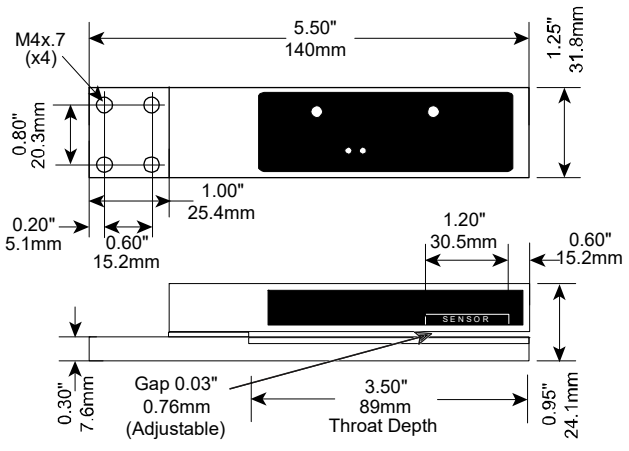

## Specifications

<b>Power Supply</b>	Voltage	11-28 V <sub>DC</sub> (reverse polarity protected)
	Current	50mA
<b>Response Time</b>	on or off	20μs max
	Switching Frequency	10kHz max
<b>Output</b>	Output Current (sinking or sourcing)	150mA max (overload protected)
	Switching Output	PNP (sourcing) or NPN (sinking), Dark or light switching
<b>Temperature</b>	Operating Range	-4°F to +140°F (-20°C to 60°C)
<b>Protections</b>	Supply	Inverse Polarity Protection
	Switching Output	Short Circuit and Overload Protection

Be confident when you do  
**business with Lion Precision.**