

Sensing Glue on Paper with Capacitive Sensors

Summary:

Water-based glue applied to a thin, nonconductive substrate such as paper, is sensed for presence/absence and/or volume using capacitive sensors.

The Problem

The application of glue to a paper substrate can be a critical piece of a manufacturing process. Detecting the presence/absence of the glue as it is applied is a preemptive measure to prevent loss of quality or product failure later in the process.

The Solution

Capacitive Sensor Operation

Capacitive sensors work with an oscillating electric field. The electric field exists between the probe and a grounded surface. The grounded surface may be the target itself (if the target is conductive), or it may be conductive material surrounding a nonconductive target.

Capacitive sensors are affected by two things: the distance between the probe and a grounded surface, and the dielectric of the material between the probe and the grounded surface.

As the amount of nonconductive material increases (which increases the dielectric), the electric field is more tightly coupled to the grounded surface, causing the sensor output to increase (Fig. 1).

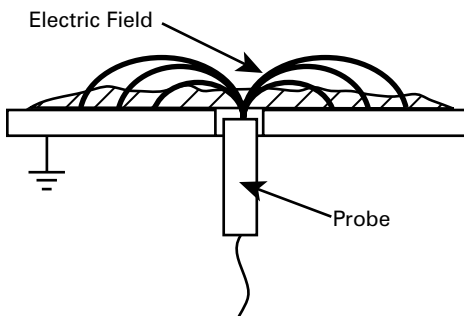

Figure 1 - Nonconductive material coupling the electric field to a grounded surface.

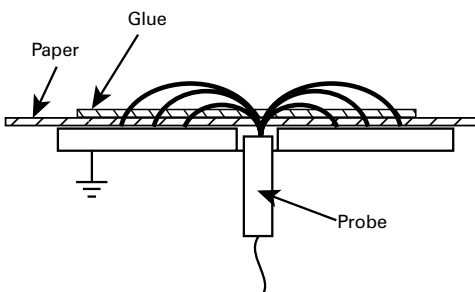

Figure 2 - Glue detection *through* paper.

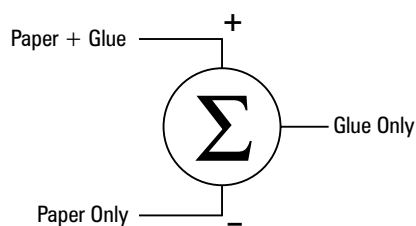

Figure 3 - Dual-Sensor usage to remove paper variations from glue measurement.

Single-Sensor Glue Sensing

Water has a very high dielectric constant making it an excellent nonconductive target for capacitive sensors. If the gap between the probe and paper/glue can be held constant, any changes in the sensor output will be a reflection of changes in the amount of glue.

To avoid contact with active adhesive, the best approach is to measure through the paper as shown in figure 2. A small gap between the probe and the paper prevents any glue seepage from contacting the probe surface.

Dual-Sensor Glue Sensing

This single-probe operation works well with thin, very dry paper which has a very low dielectric. If the paper is thicker or the environment varies in humidity, a second probe may be used to monitor the paper, away from the glue. The paper measurement is then subtracted from the glue measurement, negating any changes resulting from changes in the dielectric of the paper (Figure 3).

Glue Thickness and Output Voltage

The sensitivity of the sensor to changes in glue thickness will depend on the composition of the glue and the calibration of the sensor. This sensitivity will have to be characterized in the application to determine proper scaling.

In Production

The output voltage of the sensor(s) will be more positive when glue is increased. In its simplest form, when the voltage drops below some experimentally determined value, the system can alert an operator or PLC that glue is no longer present.

In more sophisticated applications, the output voltage may be used as feedback in a glue volume servo system.

Cautions

Probe Mounting

When measuring through paper, it is important that a grounded surface be as near as possible to the probe. The best application mounts the probe through a hole (without any counterbore) in a grounded metal plate over which the paper/glue will travel. This surrounds the probe with a grounded surface at minimum distance which provides maximum sensitivity to the glue.

Glue Composition Variation

Measurements are dependent on the composition of the glue. Should the composition change (more or less water), the output of the sensor will indicate more or less glue volume. This is of much less concern in a presence/absence application.

Recommended Equipment

Probe

Ideally, the glue area should completely cover the sensing area of the probe. The other selection factor is mounting considerations. A common choice is the C6-D probe which features a 5mm probe body, a "D" sized sensing area

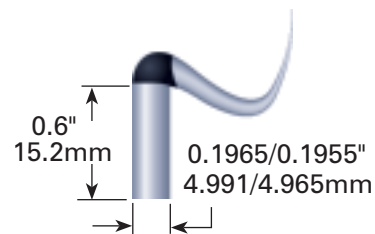

C6-D Probe

(2mm/0.79" diameter), and a 90° cable exit.

Driver Electronics

Compact Driver

The compact driver features up to six sensing channels and a small footprint in an enclosed housing. The Compact Driver has a low-noise output and requires a $\pm 15\text{VDC}$ power supply and has no user adjustments.

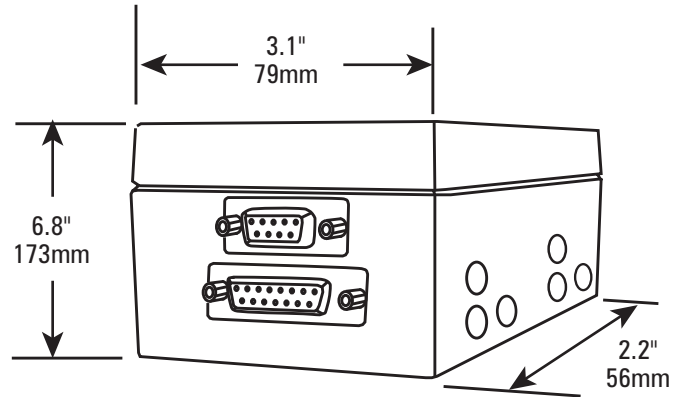

PM755

The PM755 driver features an open-frame design and can operate from $\pm 15\text{VDC}$ or 115VAC. It provides a single sensing channel and an analog or NPN switched output. The output type is selected with a jumper setting. Only one output is available at a time. Includes Gain and Zero adjustments.

