

**INSTRUCTION  
MANUAL**

---

***TARGA III***  
**Dynamic Runout System**

**LION**  
**PRECISION**

## Welcome

---

Congratulations on your purchase of a Lion Precision TARGA III Dynamic Runout measurement system. This manual will provide you with all the information you require to get the greatest benefit from your system.

Engineers and maintenance personnel will find the TARGA III invaluable for high precision measurement of dynamic runout at speeds up to 300,000 RPM.

## Calibration

---

Your system was calibrated with the Lion Precision Ultimate Calibrator. This calibrator was designed by Lion Precision and includes a state-of-the-art air slide and motion control system for high-precision calibrations. All of our calibrations are traceable to NIST. Data on the calibration sheets refer to the calibration of the probe when measuring a 1/8" gage pin. When other size pins are used, the system applies a correction factor to maintain an accurate reading. For specifications on the measurement of TIR and Dynamic Runout, see the specifications section at the end of this manual.

Replacement probes must be calibrated to the electronics.  
Replacing the probe without calibration can result in errors of up to 10%.

## Help

---

If you require assistance, please visit our web site to find your local representative: [www.lionprecision.com](http://www.lionprecision.com).

Or you may contact us directly:

651-484-6544

[support@lionprecision.com](mailto:support@lionprecision.com)

## Overview

---

The TARGA III system is designed to measure and display the dynamic runout of high-speed spindles. While it is designed specifically for the PCB drilling industry, it can measure any spindle that can rotate a gage pin. Understanding the relationship between runout and RPM provides information on the best drilling speeds and can indicate out-of-spec spindles.

## Basic Measurement Sequence

---

1. Insert gage pin into spindle.
2. Position the probe near the gage pin and center the probe on the gage pin (see figure).
3. Adjust probe distance to gage pin until the Calibrated Range indicator is in middle of range.
4. Select the appropriate gage pin size on the display module.
5. Select DRO function on the display module.
6. Run spindle at various operating speeds and read Dynamic Runout (DRO) on the display.

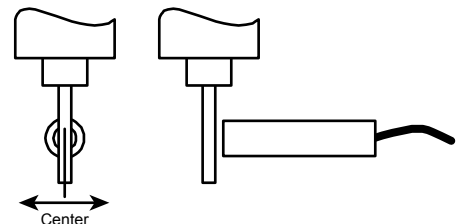

## Probe Driver

---

### Calibrated Range Indicator Bar

Green LEDs indicate that the probe is in its calibrated range and the output voltage is an accurate representation of the target position. Red LEDs indicate that the probe is out of range and the displayed value and output voltage are not valid.

### Ground

A banana-plug cable can be connected here for grounding the target. In most cases, separate grounding of the target is not necessary. If the target is not grounded through another path, and the output exhibits excessive electrical noise, grounding the target may reduce the output noise. When low-noise operation is critical, separate grounding is recommended even if the target is well grounded through another path.

### Probe Connector

Connect the probe by aligning the red dots on the connectors and inserting the probe connector.

To disconnect the probe, pull on the knurled barrel of the probe connector to release it.

DO NOT PULL ON THE CABLE.

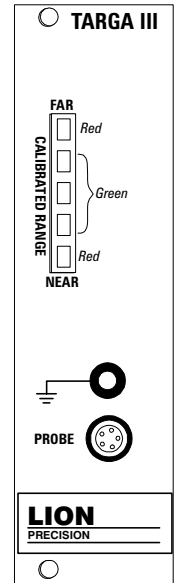

## Meter/Display Module

The Meter/Display Module displays dimensional values derived from sensor. The displayed value is also provided as an analog voltage at the front panel BNC “Output” connector.

### Capabilities

- Displays dimensional units derived from sensor output voltages
- Peak capture functions including Dynamic Runout (DRO)
- Meter/Inch unit selection
- Analog voltage output proportional to displayed value

### Meter/Display Module Setup

Pressing the appropriate button repeatedly rotates through selections.

1. Select pin diameter
2. Select a peak function (usually DRO)
3. Select meter or inch units

#### Pin Diameter

For accurate measurements, the Targa III must know the size of the pin used as a target. Three choices are available: 1/8", 2mm, and 1.5mm. Press the button to select the appropriate pin size.

The system is calibrated for a measurement range of 250 $\mu$ m (0.01") with a 1/8" pin. The calibrated range is directly proportional to the pin diameter. Smaller diameter pins have a slightly reduced range.

#### Display Units

The Meter/Display module measures the analog voltage from the sensor and uses digital signal processing to perform peak capture functions. The result is converted to dimensional units for display. The multiplier indicators (milli, micro) combined with the Meter or Inch units indicate the dimensions of the displayed value. The Units button selects either Meter or Inch units.

#### Peaks

Five options are available:

NONE – Display is real-time measurement value (probe/pin gap).

MAX – Displays the most positive value since the last reset (RST).

MIN – Displays the most negative value since the last reset (RST).

TIR – Displays the maximum difference between the MAX and MIN values since the last Reset (RST). TIR is always a positive value.

DRO – Dynamic Runout displays the *current* difference between the MAX and MIN values. When the TIR value is reduced, the displayed value will decay to the lower value within approximately one second.

#### Analog Output (BNC)

Provides an analog output voltage proportional to the displayed value. With non-TIR readings (NONE, MAX, MIN), the output is  $\pm 5$ VDC; With TIR and DRO readings, output is 0-10VDC. When “Meter” units are selected, the output voltage scaling is 25 $\mu$ m/V; with “Inch” units, the output scaling is 0.001"/V.

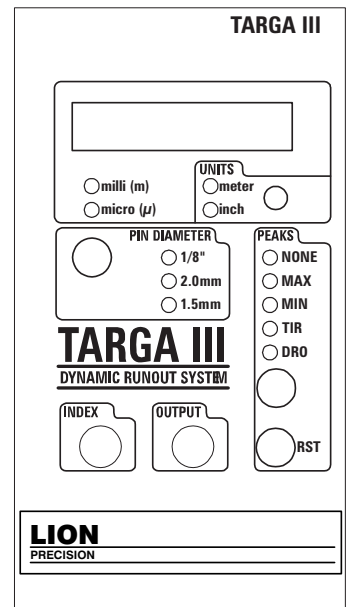

## Index

If the Targa III is used with an external data acquisition system and computer, then it is possible for the computer to use the Index input to calculate RPM. If your Targa III is not supplied with a separate data acquisition system, then the Index input is not used. The Targa III system does not measure or display RPM directly. For more detail on this application, see Lion Precision TechNote – LT03-0026 Targa III Index Connector Usage available at [www.lionprecision.com](http://www.lionprecision.com); click on Technical Library.

## Specifications

General Specifications	
<b>BNC Output Voltage</b>	0-10VDC – TIR, DRO Modes ±5VDC – Other modes
<b>BNC Output Voltage Scaling</b>	Meter units: 25µm/V Inch units: 0.001"/V
<b>BNC Output Resolution</b>	625nm, 0.000,025"
<b>Display Resolution</b>	0.5µm, 0.000,02"
<b>Measurement Range</b>	250µm, 0.010" (1/8" pin)
<b>Near Gap</b>	125µm, 0.005" (1/8" pin)
<b>System Power In</b>	±15VDC @ 0.25A
<b>External Power Supply</b>	Output: +15VDC; 1.6A -15VDC; 0.8A  Input: 100-240VAC, 50/60Hz

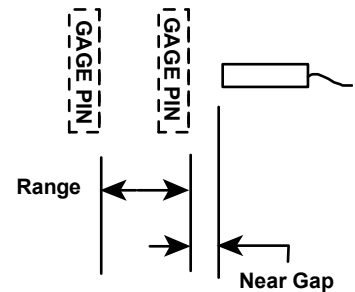

Measurement Error as a Function of Spindle Speed and Average Gap				
Average Gap µm	% of Actual TIR			
	100,000 RPM	180,000 RPM	300,000 RPM	600,000 RPM
150	±1%	+1% to +3%	+1% to +4%	0% to +10%
250	±1%	±1%	±2%	-8% to -18%
350	±1%	-1% to -3%	-3% to -7%	-20% to -40%

## Power Input Connector

Pin	Connection
1	Ground
3	-15VDC
4	+15VDC

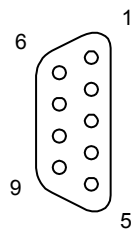

Power Connector  
Pin Numbers  
Viewed from Rear Panel

## System Mechanical Detail

---

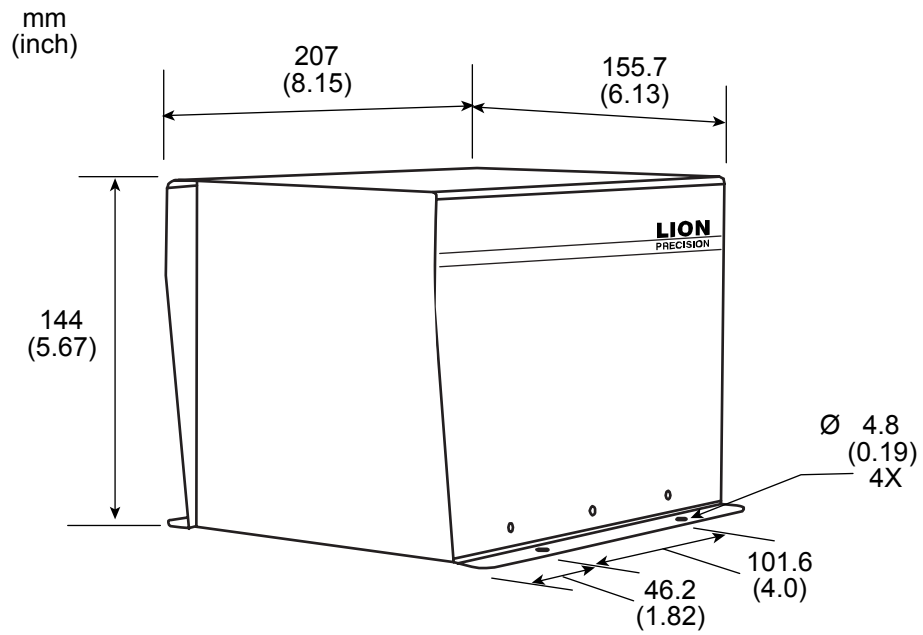

## External Power Supply Mechanical Detail

---

