

Mechanical Detail

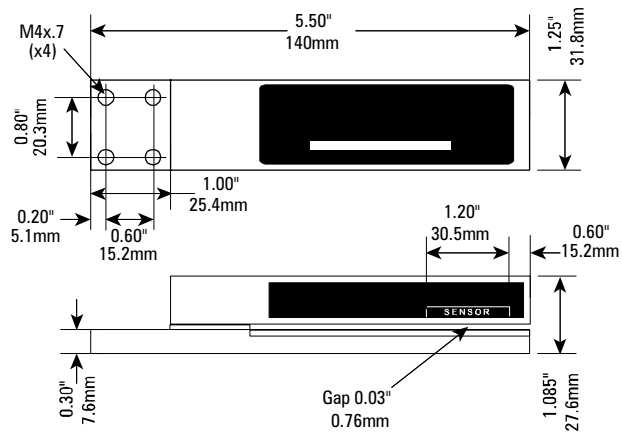

User's Guide
for the
LRD6110C Label Sensor
from
Lion Precision

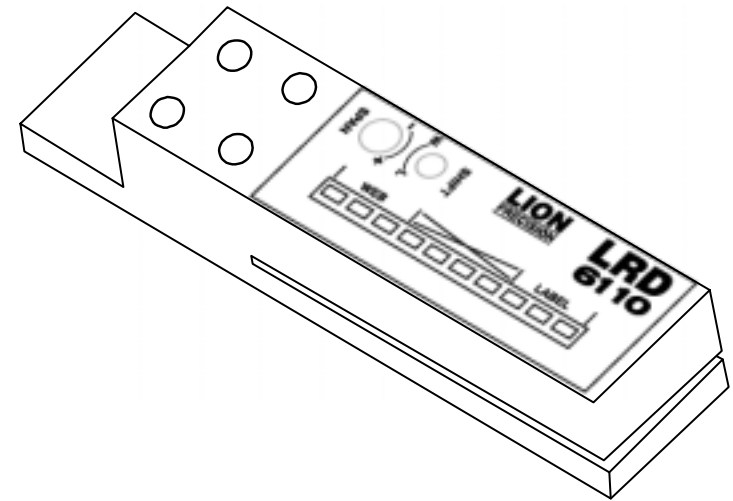

TWO YEAR WARRANTY

AUTOMATED QUALITY TECHNOLOGIES INC., and its division LION PRECISION warrants to the Purchaser that the LRD Product will be free from defects in material and workmanship and will be in conformance with the Purchaser's specifications when such specifications are accepted by specific contract. The foregoing warranty is exclusive and in lieu of all other warranties whether written, oral, or implied (including any warranty of fitness for purpose). If it appears within two years from the date of shipment by the Corporation that the equipment as delivered does not meet the warranties specified above and the Purchaser so notifies the Corporation promptly, the Corporation shall correct any defect, including non-conformance with the specifications, at its option, either by repairing any defective part(s), or by making available at the Corporation's plant, a replacement or required part.

The above warranty is null and void if the equipment is used or serviced in a manner that does not conform to the ratings and specifications as defined by the Corporation or if the equipment has been damaged or altered. The foregoing shall constitute the sole remedy of the Purchaser and the sole liability of AUTOMATED QUALITY TECHNOLOGIES, INC.

<p>Lion Precision 563 Shoreview Park Road St. Paul, MN 55126 651-484-6544 www.lionprecision.com Document Number: M015-3382.012</p>	
---	--

Description

The LION PRECISION LRD6110C LABEL REGISTRATION AND DETECTION SYSTEM is an electronic capacitive sensor used to monitor label registration and/or count labels. The sensor will output a signal indicating the leading or trailing edge of the label as it passes through the sensor.

Connecting to the Sensor

Warnings:

Sensor body is connected to Ground.

Unused wires must be insulated from contact with other objects.

All power must be off when installing the sensor.

Gray wire (Output Polarity, pin 5) must be connected to +V or Ground for reliable operation.

Wire Color	Connection	Notes
1 (Brown)	+Vin (11-28VDC)	50mA max.
2 (White)	NPN Output	150mA max.
3 (Blue)	Ground	Connected to sensor body
4 (Black)	PNP Output	150mA max.
5 (Gray)	Output Polarity (light/dark switching)	+V – Dark Switching (NC) Ground – Light Switching (NO)

Warning: Gray wire (pin 5) must be connected to +V or Ground for reliable operation.

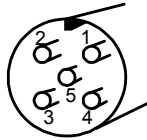
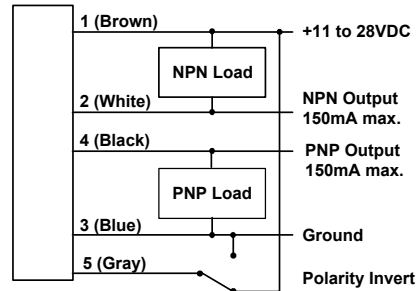

Connector on rear of sensor

Specifications

Power supply	Voltage	11-28 VDC (reverse polarity protected)
	Current	50mA
Response time	on or off	10µs max
	Switching Frequency	10kHz max
Output	Output Current (sinking or sourcing)	150mA max (overload protected)
	Switching output	PNP or NPN, dark or light switching
Temperature	Operating Range	40°F to 140°F (4°C to 60°C)
Protections	Supply	Inverse Polarity Protection
	Switching output	Short Circuit and Overload Protection

Setup Procedure

1. Web must remain in contact with the mounting plate.
2. Label must pass under the [-SENSOR-] indicator.
3. Small labels should be centered under the [-SENSOR-] indicator.
4. When properly setup, the lights will move between WEB and LABEL. The lights in the "X" region should only light briefly during the transition between WEB and LABEL regions.

Sensor Setup

1. Turn Span at least four turns counter-clockwise, then two turns clockwise (this is the mid-point of the adjustment range)
2. Place web (liner) only in sensor
3. Adjust Shift until LED #2 is on, then adjust Shift just to the point where LED #1 is on.
4. Slowly move a label gap through the sensor and verify that the indicator lights LED#1 as the gap passes through the sensor. If it does not, adjust Shift as necessary until it does.
5. Setup complete

If the setup does not give reliable results (usually for labels less than 1"), turn Span four turns clockwise (maximum gain) and repeat steps 2-5. It is important that the indicator only cross the "X" region during transition from web to label.

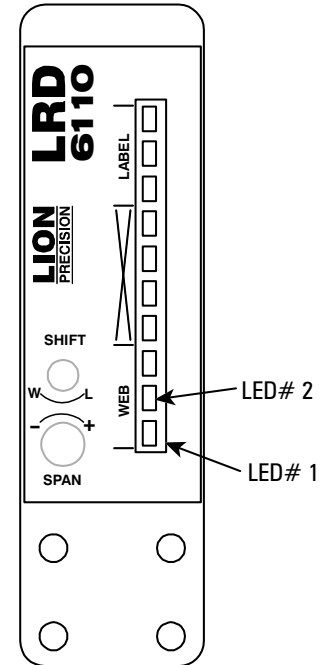

Notes:

- 1) The LRD6110 may not work reliably with solid foil labels. Some inks, usually black, have a high carbon content. If the label is flood coated (100% coverage) with the ink it may behave like a solid foil label.
- 2) For solid foil labels, use the UltraLRD V2