

**Mechanical Detail**

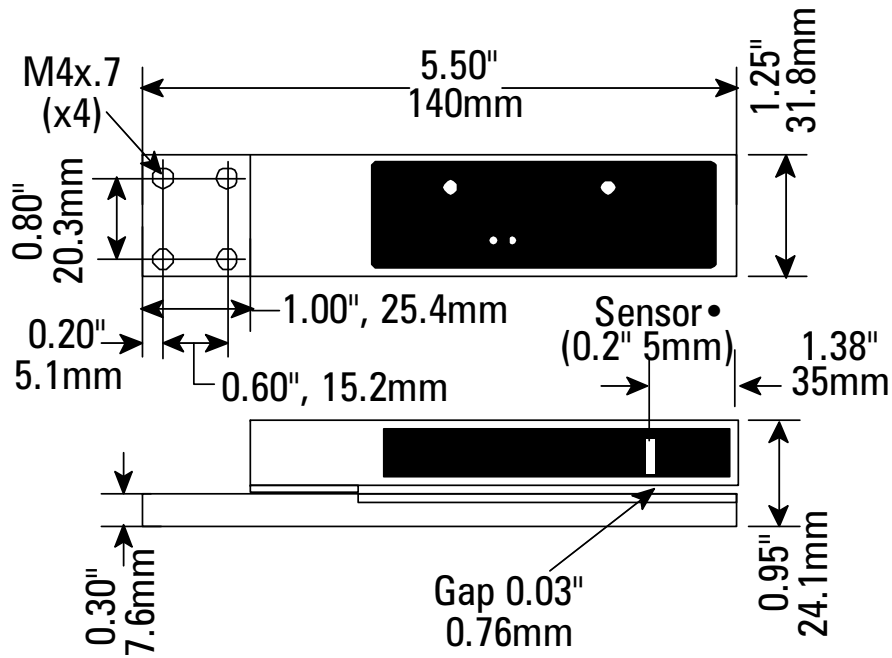

**User's Guide**  
for the  
**LRD5100 Tear-Tape Sensor**  
from  
**Lion Precision**

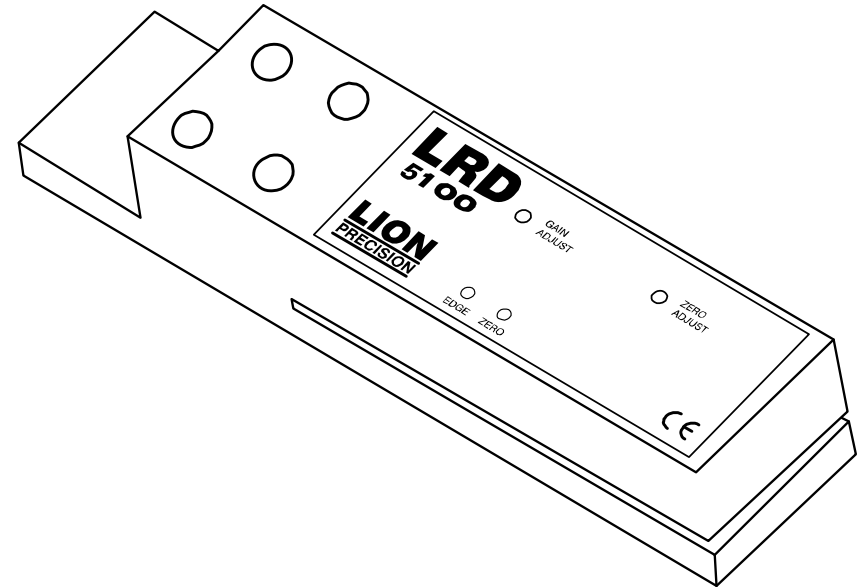

**TWO YEAR WARRANTY**

AUTOMATED QUALITY TECHNOLOGIES INC., and its division LION PRECISION warrants to the Purchaser that the LRD Product will be free from defects in material and workmanship and will be in conformance with the Purchaser's specifications when such specifications are accepted by specific contract. The foregoing warranty is exclusive and in lieu of all other warranties whether written, oral, or implied (including any warranty of fitness for purpose). If it appears within two years from the date of shipment by the Corporation that the equipment as delivered does not meet the warranties specified above and the Purchaser so notifies the Corporation promptly, the Corporation shall correct any defect, including non-conformance with the specifications, at its option, either by repairing any defective part(s), or by making available at the Corporation's plant, a replacement or required part.

The above warranty is null and void if the equipment is used or serviced in a manner that does not conform to the ratings and specifications as defined by the Corporation or if the equipment has been damaged or altered. The foregoing shall constitute the sole remedy of the Purchaser and the sole liability of AUTOMATED QUALITY TECHNOLOGIES, INC.

**Lion Precision**  
563 Shoreview Park Road  
St. Paul, MN 55126  
651-484-6544  
www.lionprecision.com  
Document Number: M014-4669.011



## Description

The LION PRECISION LRD5100 TEAR-TAPE SENSOR is an electronic, capacitive sensor used to monitor the presence on tear-tape on a film base. The sensor's NPN and PNP outputs indicate the presence or absence of the tear-tape.

The sensor works with all types of tear-tape materials on nonmetallic film backing.

## Connecting to the Sensor

### Warnings:

Sensor body is connected to Ground.

Unused wires must be insulated from contact with other objects.

All power must be off when installing the sensor.

Wire Color	Connection	Notes
Red	+Vin (11-28VDC)	50mA max.
Black	Ground	Connected to sensor body
Green	NPN Output	150mA max., 90V max.
Blue	PNP Output	150mA max. Source from +Vin
Brown	No Connection	

## Specifications

<b>Power supply</b>	Voltage	11-28 VDC (reverse polarity protected)
	Current	50mA
<b>Response time</b>	on or off	20 $\mu$ s max
	Switching Frequency	10kHz max
<b>Output</b>	Output Current (sinking or sourcing)	150mA max (overload protected)
	Switching output	PNP or NPN
<b>Temperature</b>	Operating Range	40°F to 140°F (4°C to 60°C)
<b>Protections</b>	Supply	Inverse Polarity Protection
	Switching output	Short Circuit and Overload Protection

## Setup Procedure

The two adjustments are four turn adjustments. Once at the end of adjustment they will continue to turn but have no effect.

### Setup for nonmetallic tear-tape

1. With web material placed in the gap of the sensor and the tear-tape properly lined up on the "STRIP" marker, adjust the ZERO control until the ZERO light just turns on.
2. Remove a section of tear-tape.
3. Pass the "tear-tape missing" and "tear-tape present" sections back and forth under the sensor. The EDGE light should flash at the transitions between missing and present tear-tape. If the EDGE light does not flash at the transitions, turn the GAIN control clockwise until it does.
4. Turn the GAIN control another ½ turn clockwise.

### Setup for metallic tear-tape

1. Center the GAIN control by turning it counter-clockwise four turns, then two turns clockwise.
2. With no material, or web material only (no tear-tape) placed in the gap, adjust ZERO until the EDGE light just turns off.
3. Turn ZERO ½ turn clockwise.
4. Verify proper operation with tear-tape present.

## Output Waveforms

