

Output and Mechanical Detail

Light/Dark switching is affected by the direction of label movement and the Output Polarity connection. Output descriptions below are for web directions as indicated in the illustrations.

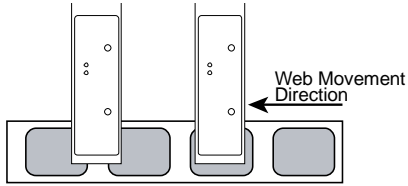

Dark Switching
Output Polarity = +V

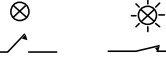

← Output Indicator*
← Outputs

Light Switching
Output Polarity = GND



← Output Indicator*
← Outputs

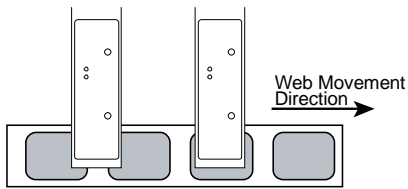

Dark Switching
Output Polarity = GND

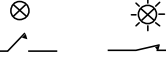

← Output Indicator*
← Outputs

Light Switching
Output Polarity = +V

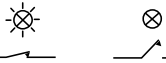

← Output Indicator*
← Outputs

*Some models label this indicator as "Edge"

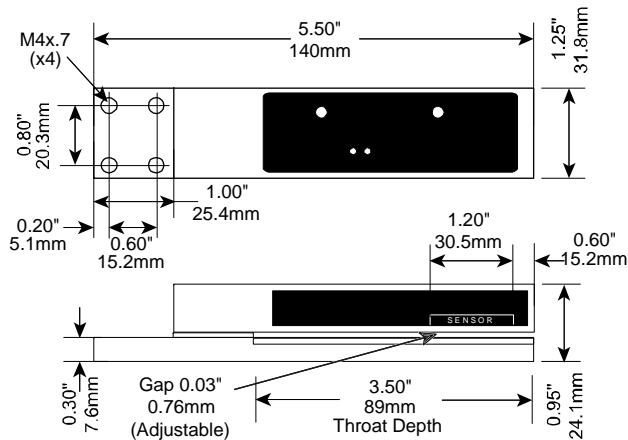

User's Guide for the LRD2100 Label Sensor from Lion Precision

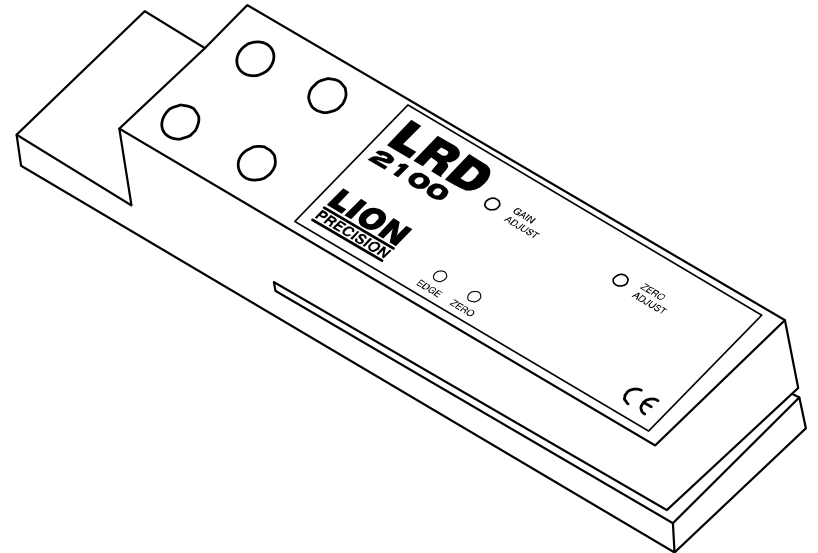

Lion Precision
563 Shoreview Park Road
St. Paul, MN 55126
651-484-6544
www.lionprecision.com
Document Number: M014-4660.023

LION
PRECISION

Description

The LION PRECISION LRD2100 is an electronic, capacitive sensor used to monitor label registration and/or count labels. The outputs indicate the edges of labels as they pass through the sensor. Use LRD6110 or UltraLRD V2 for metallic labels, metallic inks, or hot stamp.

Connecting to the Sensor

Warnings:

Sensor body is connected to Ground.

Sensors must not be attached to voltages in excess of 30VRMS or 60VDC

All external connections must be SELV (Safety Extra Low Voltage).

All power must be off when installing the sensor.

Brown wire must be connected to +V or Ground for reliable operation.

Use of the equipment in any other manner may impair the safety and EMI protections of the equipment.

Wire Color	Connection	Notes
Red	Vin (11-28V _{DC})	50mA max.
Black	Ground	Connected to sensor body
Green	NPN Output	150mA max.
Blue	PNP Output	150mA max.
Brown	Output Polarity (light/dark switching)	+V or Ground See detail on back
Warning: Brown wire must be connected to +V or Ground for reliable operation.		

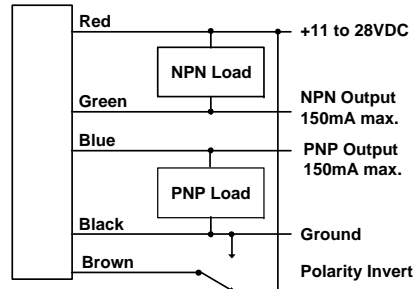

Specifications

Power supply	Voltage	11-28 V _{DC} (reverse polarity protected)
	Current	50mA
Response time	on or off	20μs max
	Switching Frequency	10kHz max
Output	Output Current (sinking or sourcing)	150mA max (overload protected)
	Switching output	PNP (sourcing) or NPN (sinking), Dark or light switching
Temperature	Operating Range	40°F to 140°F (4°C to 60°C)
Protections	Supply	Inverse Polarity Protection
	Switching output	Short Circuit and Overload Protection

Setup Procedure

These sensors are extremely stable and should not require re-adjustment after the initial setup. Re-adjustment will only be required for significant changes in label shape or thickness, or changes in power supply voltage.

1. Remove all material from sensor.

2. Center GAIN ADJUST

Turn GAIN ADJUST four (4) turns counter clockwise.
Turn GAIN ADJUST two (2) turns clockwise.

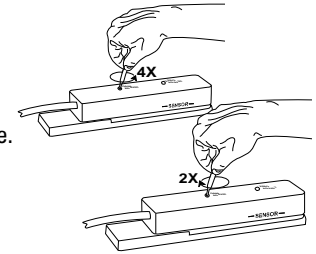

3. Set ZERO ADJUST

Set ZERO ADJUST to the point where the ZERO light just begins to come on.

It is not important whether the light is on or off. What is important is that the light is very near the point where it changes from off to on.

4. Set GAIN ADJUST

For most labels, GAIN will need no further adjustment. If the sensor performs erratically, use this GAIN adjustment procedure.

Insert material into sensor.

While moving labels through the sensor, Set GAIN ADJUST to the point where the OUTPUT light (EDGE on some models) starts to flash. Then continue turning ½ turn clockwise.

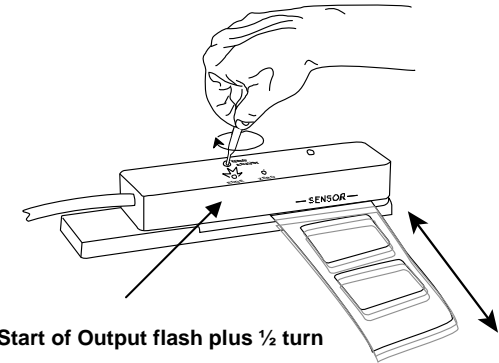

5. Sensor is now ready.

Lights During Operation:

The Output light (Edge on some models) indicates the sensor output. It will be in one state (on or off) during the label and the other state during the gap depending on the direction of the label movement and the connection of the Polarity Invert wire (see next page for details).

The Zero light is for setup only and is meaningless during operation.

Notes:

- 1) For best results, web should ride against sensor baseplate, not "float" in the gap.
- 2) Some inks, usually black, have a high carbon content. These inks behave like metal and may not work reliably with the LRD2100. Use the LRD6110 instead.