

# INSTRUCTION MANUAL

---

## ECL130 Compact Driver

Measurement Systems  
from  
LION PRECISION

# Table of Contents

<b>WELCOME .....</b>	<b>2</b>
SYSTEM CONTENTS .....	2
IDENTIFYING PROBE/CHANNEL.....	2
CALIBRATION .....	2
USING THIS MANUAL .....	3
HELP.....	3
<b>PROBE INSTALLATION.....</b>	<b>4</b>
<b>CONNECTING TO THE ECL130.....</b>	<b>4</b>
PROBE CONNECTIONS.....	4
POWER SUPPLY CONNECTIONS .....	5
<i>Power Supply Requirements</i> .....	5
<i>With Enclosure</i> .....	5
<i>Power Connector (J1) Pin Assignments</i> .....	5
<i>Without Enclosure</i> .....	5
ANALOG OUTPUT CONNECTIONS.....	5
ANALOG OUTPUT CONNECTIONS.....	6
<i>Single-Ended Outputs</i> .....	6
<i>Differential Outputs</i> .....	6
<i>Output Connector (J2) Pin Assignments</i> .....	6
<b>FACTORY CALIBRATION.....</b>	<b>7</b>
<b>FIELD CALIBRATION.....</b>	<b>7</b>
<b>MECHANICAL DATA.....</b>	<b>8</b>
ENCLOSURE .....	8
WITHOUT ENCLOSURE.....	9
<b>APPENDIX.....</b>	<b>10</b>
PCB CONNECTOR DETAIL .....	10
<i>JP1 Jumpers</i> .....	11

## Welcome

---

Congratulations on your purchase of an ECL130 Inductive Compact Driver System. This manual will provide you with all the information you require to get the greatest benefit from your system.

Engineers, technicians, and maintenance personnel will find the ECL130 invaluable for high-precision measurements of mechanical displacement where contact with the target is not possible nor advisable.

The Lion Precision ECL130 is very flexible. Your system may have been ordered with one to six channels of gauging and with or without an enclosure.

### System Contents

Your system includes this manual, the ECL130 with or without enclosure, and one probe for each channel. Each channel has been specifically calibrated to a probe according to the specifications on your order. For this reason, each probe is labeled for a particular channel. Be sure the probes are used with the proper channel.

<p><b>CAUTION:</b> Be sure to use probes with their proper channels.</p>
--

### Identifying Probe/Channel

Individual probes are calibrated to specific channels of specific systems. Probes are labeled at the connector end.

When ordering multiple systems it is important that probes are connected to the correct ECL130. For example, if you have three systems and you are holding a probe marked for channel 2, it must be connected to channel 2 of the correct ECL130.

Each ECL130 has calibration labels. Each label lists a probe serial number that is calibrated to that ECL130. To locate the correct ECL130 for a probe, match the probe's serial number (shrink sleeve near connector end) to the ECL130 with a calibration label listing the probe's serial number. The probe has a cable tag indicating the calibrated channel.

### Calibration

Most systems are calibrated with the Lion Precision Ultimate Calibrator. This calibrator was designed by Lion Precision and includes a state-of-the-art air slide and motion-control system. This has enabled us to calibrate with microinch precision. All of our calibrations are traceable to NIST.

## **Using this manual**

In this manual you will find information for connecting to your ECL130 and instructions on setting up probe position. Once you become familiar with the system, you will only need to refer occasionally to this manual for specifications or to verify connection information.

## **Help**

Lion Precision wants to help you get the most from your system. If there is anything we can do, call or fax us at these numbers:

Telephone: 651-484-6544

Fax: 651-484-6824

Or, you can email us:

General information: [info@lionprecision.com](mailto:info@lionprecision.com)

Service or calibration: [support@lionprecision.com](mailto:support@lionprecision.com)

Sales: [sales@lionprecision.com](mailto:sales@lionprecision.com)

Or you can visit our website:

[www.lionprecision.com](http://www.lionprecision.com)

On the website you'll find application notes, product manuals, theory of operation of capacitive probes, a complete listing of our product line, etc. There's also a form you can fill out to request information or help.

## Probe Installation

Any conductive material that engages the coil field will influence the output of the sensor. Follow the guidelines shown below for shielded and unshielded probes. If it is not possible to meet these minimum guidelines, contact Lion Precision for help.

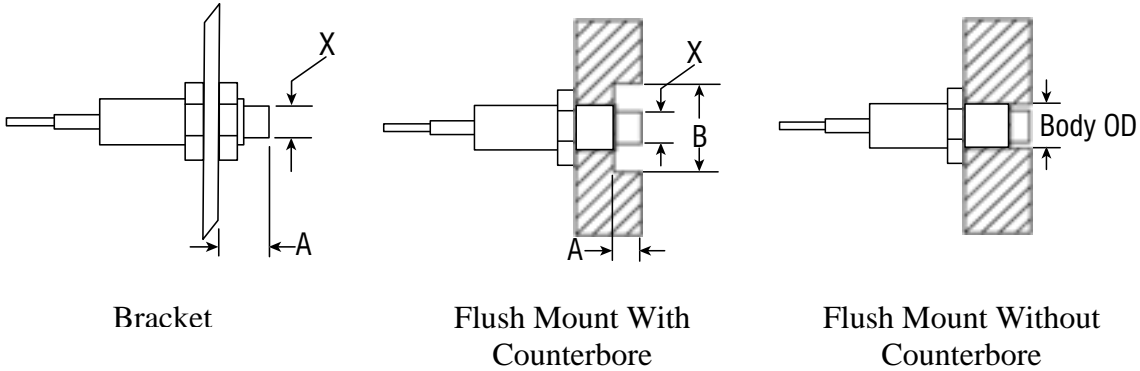

Dimensions Relative to X		
	A	B
Unshielded	1.5X	3X
Shielded	1X	2X

Flush mount without counterbore recommended for shielded probes only. Requires special calibration. Contact Lion Precision for more information.

## Connecting to the ECL130

### Probe Connections

The ECL130 has one probe connector per channel. Each probe is tagged with its designated channel.

To connect the probes:

1. Insert the probe connector into the corresponding ECL130 connector .
2. Do not rotate the connector.

The probes *must* be connected to their designated channels for proper operation.

**CAUTION:**  
Be sure to use probes with their proper channels.

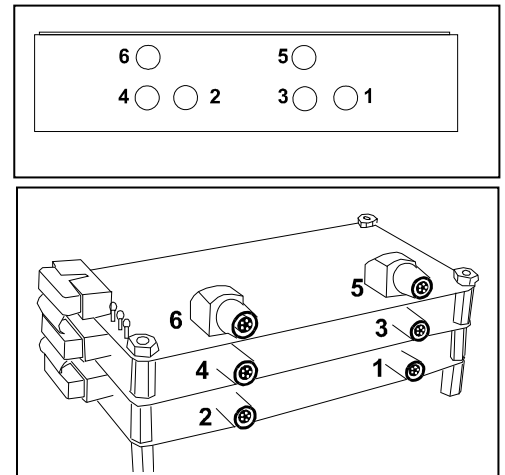

## Power Supply Connections

### Power Supply Requirements

Required power input is  $\pm 12$  to  $\pm 15$ VDC. Any high-frequency noise on the power supply lines may appear in the output.

*For high-resolution results, be sure to provide clean power.*

### With Enclosure

Connect power through the nine pin male D-Sub Power connector, J1, or fifteen pin female D-Sub Output connector, J2. (J2 connection detail is on the next page).

### Power Connector (J1) Pin Assignments

(Mounting hardware is 4-40 thread)

**CAUTION:**  
Reversed  
power  
connections  
may destroy  
the system!!

J1 (Power Only)	
Pin	Connection
1	Ground
2	NC
3	-12 to -15VDC
4	+12 to +15VDC
5	NC
6	NC
7	NC
8	NC
9	NC

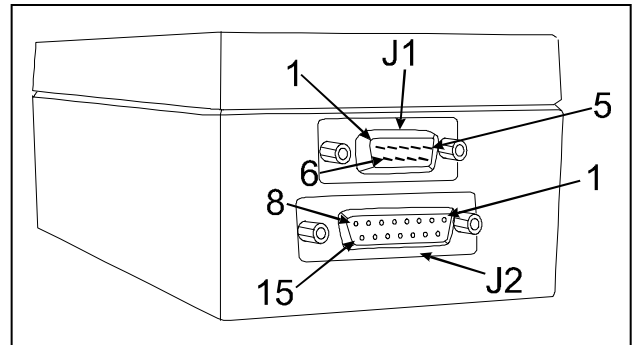

ECL130 Input/Output Connections

### Without Enclosure

Connect power through the provided fifteen pin female D-Sub (see table J2 below), or power can be connected to three pin header, J3.

PCB J3 Power	
Pin	Connection
1	+12 to +15VDC
2	Ground
3	-12 to -15VDC

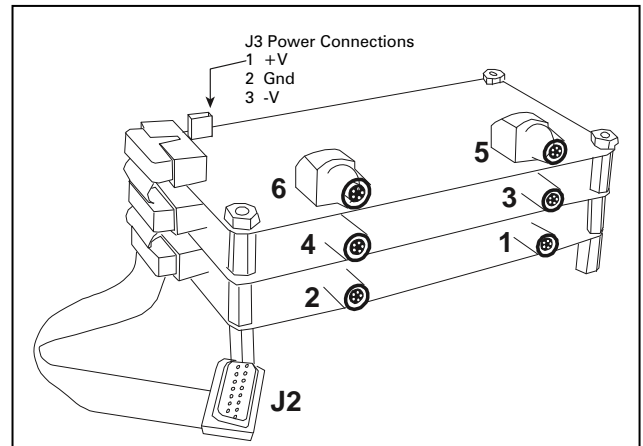

Probe channel configuration and optional power supply connector for system without enclosure.

## Analog Output Connections

Analog outputs for each channel are provided by a fifteen pin female D-Sub connector (J2). See table J2 for pinout (mating connector is provided with the system). Analog outputs are available for single-ended or differential.

### Single-Ended Outputs

The (+) output or (-) output can be used with a ground connection for single-ended output. The (+) output voltage becomes more positive as the probe moves away from the target. The (-) output voltage becomes more negative as the probe moves away from the target. Both the (+) and (-) outputs are  $\pm 10\text{VDC}$ .

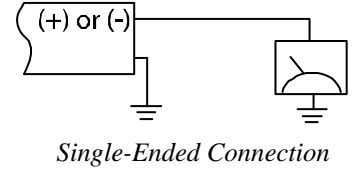

### Differential Outputs

The (+) and (-) outputs can be used together as a differential output. Differential outputs can help eliminate electrical noise that may be induced into the output connecting wires by noise sources such as computers, power transformers etc.

Differential mode produces twice the sensitivity of single-ended mode. For example, a 1V/mm single-ended output will be 2V/mm in differential mode. The calibration sheet indicates whether the system was calibrated in differential or single-ended mode.

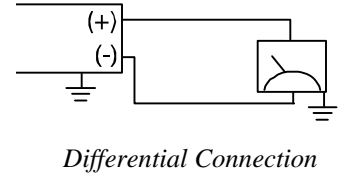

The analog output connector is configured to allow for twisted pair ribbon cable usage in differential mode.

While the signal is derived from the (+) and (-) outputs when used differentially, ground connections of the sensor system and the system to which the outputs are connected are still recommended.

### Output Connector (J2) Pin Assignments

(Mounting hardware is 4-40 thread)

Differential output measurements have twice the sensitivity of single-ended output measurements.

<b>J2 (Analog Out and Power)</b>			
<b>Pin</b>	<b>Connection</b>	<b>Pin</b>	<b>Connection</b>
1	Ch1+	9	Ch1-
2	Ch2+	10	Ch2-
3	Ch3+	11	Ch3-
4	Ch4+	12	Ch4-
5	Ch5+	13	Ch5-
6	Ch6+	14	Ch6-
7	+12 to +15VDC	15	Ground
8	-12 to -15VDC		

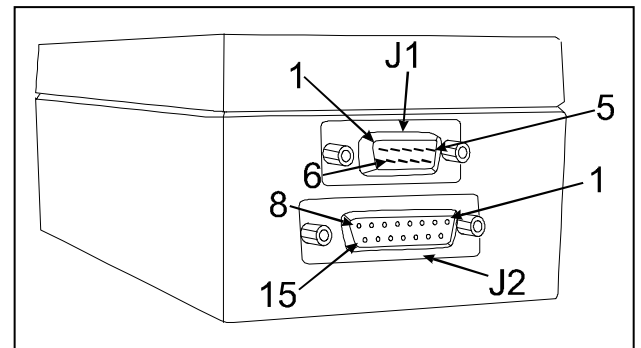

*Compact Driver Input/Output Connections*

## Factory Calibration

The ECL130, when purchased with a probe(s), comes calibrated to a standard or customer specified standoff and range. Refer to the supplied calibration record for specific calibration information.

## Field Calibration

Any change in these adjustments will void the NIST traceable calibration certificate shipped with the sensor. The sensor can also be returned to the factory for NIST traceable recalibration. Contact Lion Precision for scheduling and pricing.

Calibration requires a suitable positioning method to set the probe/target gap to Near, Standoff, and Far positions as required for the calibration. Contact Lion Precision for assistance.

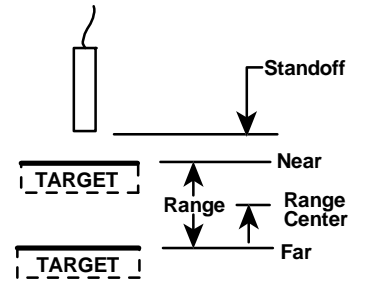

*Definition of Terms*

1. Set the gap to standoff (Range Center).
  2. Set the output to 0.000VDC with the Coarse and Fine Zero adjustments.
  3. Set the gap to Near (smallest gap).
  4. Set the output to -10.000VDC using the Gain adjustment.
  5. Set the gap to Far (largest gap).
  6. Set the output to +10.000VDC using the Coarse and Fine Linearity adjustments.
  7. Because the adjustments interact, repeat steps 1-6 as needed.
- Hint:** When adjusting linearity, adjust the output for the same but opposite amount of error voltage. For example, if the output is 9.950VDC adjust it to 10.050VDC. This will shorten the total number of iterations of steps 1-6. As the linearity adjustment approaches 10 volts, use Fine Linearity for finer control.

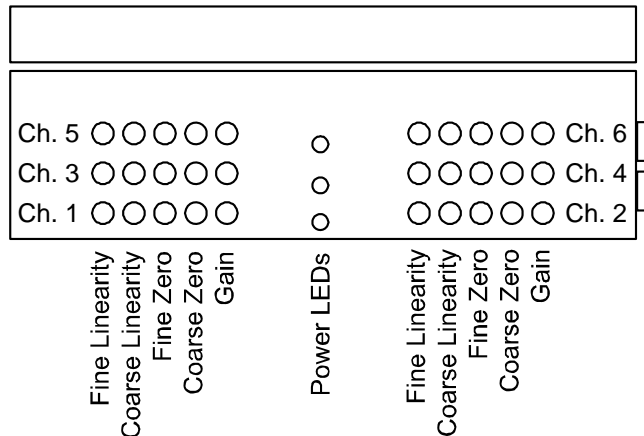

# Mechanical Data

## Enclosure

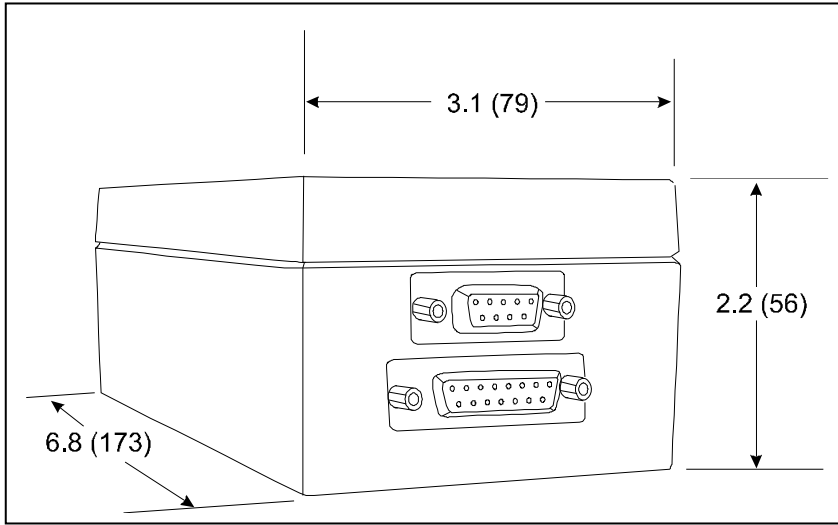

*Outside Dimensions  
inch (mm)*

All dimensions in mm

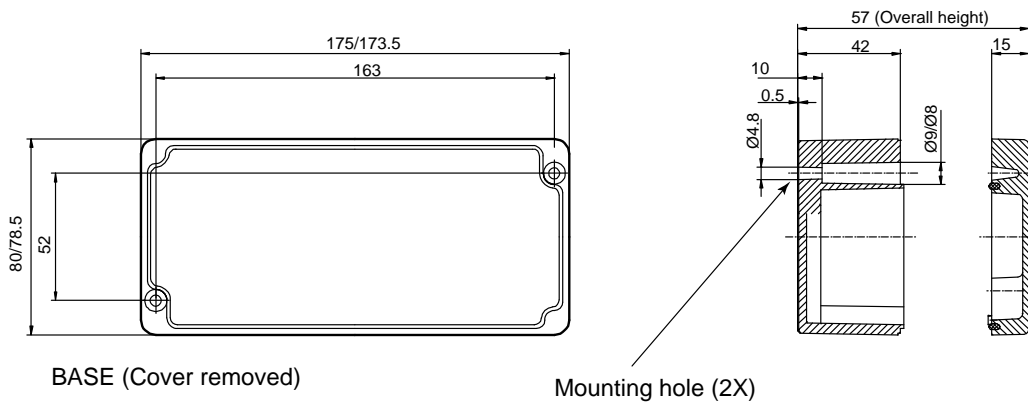

*Mounting Hole Locations  
mm*

The cover must be removed to access the two mounting holes. The mounting holes provide a 4.8mm thru-hole at the bottom of the enclosure with a 8/9mm tapered counterbore to allow for the screw head. The spacing of the mounting holes is embossed on the bottom of the enclosure.

### Without Enclosure

Inches(mm).

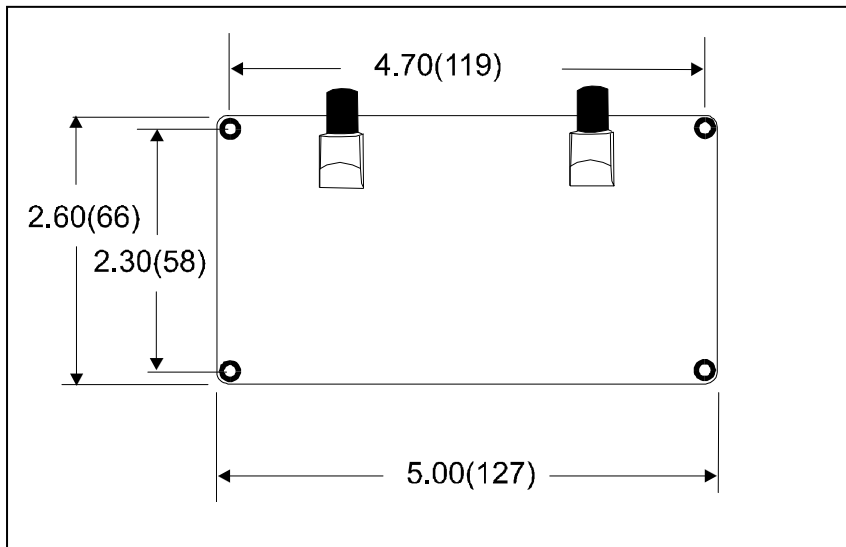

## Appendix

### PCB Connector Detail

For non-enclosed systems, power and output connections can be made through a 90°, 16 pin, dual row header J1. This connector is designed to receive a standard 16 pin dual row socket for ribbon cable connection.

The DC power connections are fixed, but the analog output connections for each channel can be configured by jumpers on JP1. This jumper block allows the analog outputs to be fed to J1 on one of three sets of pins. In multiple channel systems, this allows for stacking of boards while using one ribbon cable connected in parallel across the stack of boards.

By default, non-enclosed systems shipped from the factory will have a single ribbon cable terminated in a 15 pin female D-Sub connector. The jumpers on JP1 are configured to make the output pins of this connector the same as the 15 pin D-Sub connector on enclosed systems.

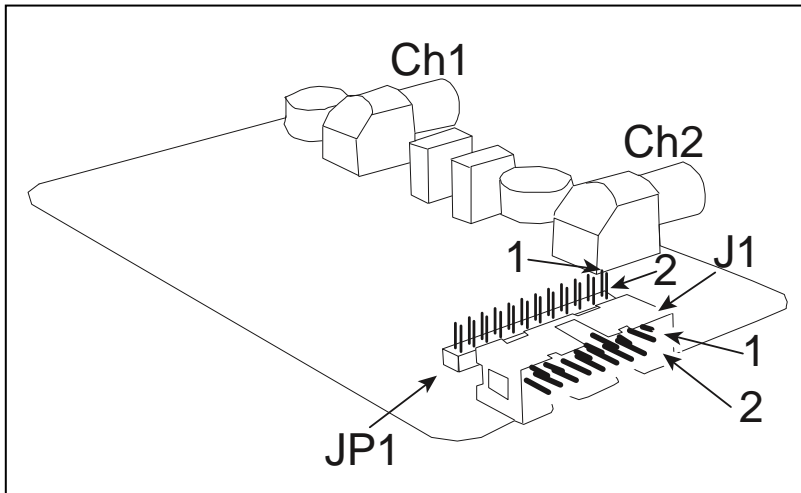

*Input/Output Connections for Compact Driver without enclosure*

	J1		
Connection (default)	Pin	Pin	Connection (default)
Analog Output + (Ch1)	1	2	Analog Output - (Ch1)
Analog Output + (Ch2)	3	4	Analog Output - (Ch2)
Analog Output + (Ch3)	5	6	Analog Output - (Ch3)
Analog Output + (Ch4)	7	8	Analog Output - (Ch4)
Analog Output + (Ch5)	9	10	Analog Output - (Ch5)
Analog Output + (Ch6)	11	12	Analog Output - (Ch6)
+12 to +15VDC	13	14	Ground
-12 to -15VDC	15	16	Ground

### JP1 Jumpers

By installing jumpers on the JP1 pins, the individual analog outputs can be routed to different pins on J1. Placing a jumper on the pair of JP1 pins indicated in the table, will route that signal to the J1 pin shown. Each analog output has three possible connections to J1. For example, channel 1 (+) output can be connected to J1 pins 1, 5, or 9.

This is useful in “stacked” systems. In such a system, the bottom board outputs can be connected to J1 pins 1,2 and 3,4; while the next board in the stack can have its outputs connected to J1 pins 5,6 and 7,8. This allows a single ribbon cable to carry all of the signals from a three board stack .

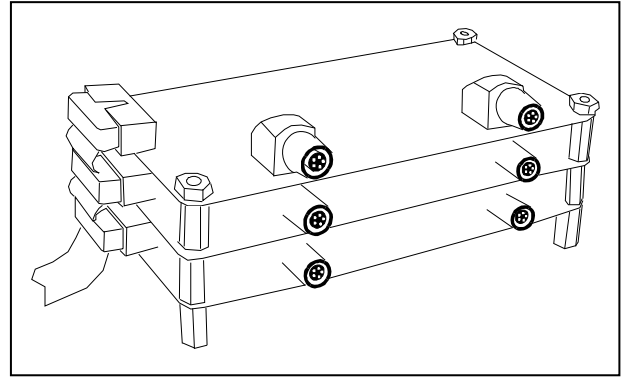

*A six channel “stacked” system with single ribbon cable.*

Analog Output	JP1 Pair		J1 Pin
	Pins		
Analog Output + (Ch1)	1	2	1
Analog Output - (Ch1)	3	4	2
Analog Output + (Ch2)	5	6	3
Analog Output - (Ch2)	7	8	4
Analog Output + (Ch1)	9	10	5
Analog Output - (Ch1)	11	12	6
Analog Output + (Ch2)	13	14	7
Analog Output - (Ch2)	15	16	8
Analog Output + (Ch1)	17	18	9
Analog Output - (Ch1)	19	20	10
Analog Output + (Ch2)	21	22	11
Analog Output - (Ch2)	23	24	12