

INSTRUCTION MANUAL

Elite Series

Capacitive
Sensor
Systems

CPL190 • CPL290 • MM190 • TMP190 • EN190

LION
PRECISION

Table of Contents

Approvals and Safety Considerations	3
Elite Series: CPL190/290 Capacitive Displacement Sensor	4
Basic Operation	4
Overview of Front Panel Controls, Indicators, and Connectors	5
Multiple Channel Measurements	6
Bandwidth Settings (Switch S2)	6
CPL190/290 Specifications ¹	7
Elite Series: MM190 Meter and Function Module	8
Capabilities	8
Setup	8
MM190 Specifications.....	9
Elite Series: TMP190 Temperature Sensing and Encoder/Index Input Module	10
Requirements	10
Operation – Temperature Sensing	10
Encoder/Index Pulse Input.....	12
TEDS (Transducer Electronic Data Sheet)	14
Elite Series Enclosures.....	15
Power Specifications	15
EN191, EN192, EN193 Power Connector.....	16
External Power Supply	16
DAQ Connector Pinout.....	17
Mechanical Specifications: EN191, EN192, EN193	18
Mechanical Specifications: EN196, EN198.....	19
CPL190/290 DIP Switch Access	20
Accessories	21
Air-Bearing C-LVDT: Capacitive LVDT-Type Contact Sensor	21

Approvals and Safety Considerations

The Elite Series is compliant with the following CE directives:

Safety: 61010-1:2001

EMC: 61326-1, 61326-2-3



To maintain compliance with these standards, the following operating conditions must be maintained:

- All I/O connecting cables must be shielded and less than three meters in length
- AC power cables must be rated at a minimum of 250V and 5A
- AC power must be connected to a grounded mains outlet rated less than 20A
- Use the included CE approved power supply with 1-, 2-, and 3- slot enclosures. If an alternative power supply is used, it must have equivalent CE certification and provide safety isolation from the mains according to IEC60950 or 61010.
- Sensors must not be attached to parts operating at hazardous voltages in excess of 33VRMS or 70VDC

Use of the equipment in any other manner may impair the safety and EMI protections of the equipment.

Elite Series: CPL190/290 Capacitive Displacement Sensor

The CPL190/290 Capacitive Sensor is a precision, noncontact measurement device. The output voltage changes in direct linear proportion to changes in the gap between the probe and the target. The sensor is normally used to measure conductive targets, but it can also be used with nonconductive targets under the right conditions. For more information about measuring nonconductors, visit the Technical Library at www.lionprecision.com or call for assistance.

Basic Operation

The output voltage is accessed via the front panel BNC connector, or by a data acquisition system via the high-density connector on the rear of the enclosure. This connector can connect directly to National Instruments™ data acquisition products. See the enclosure section of this manual for specifics on the system DAQ connector (page 16).

As the gap between the probe and target changes, the output voltage will change accordingly. As the probe approaches the target, the output voltage will become more positive.

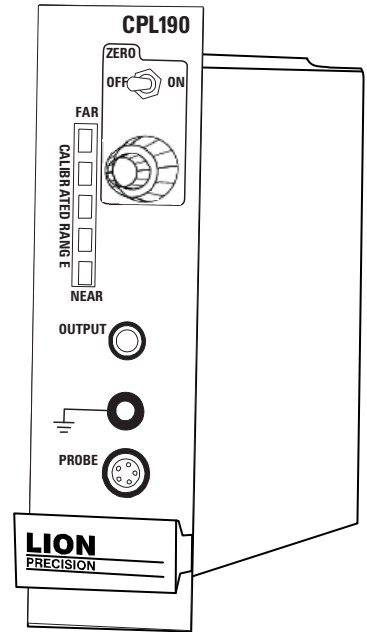

Note: Calibrated Range “Near” and “Far” lights (red) indicate that the probe is out of its calibrated range and the output is not guaranteed to be accurate even though the voltage may continue to change.

Probes are calibrated to specific modules. With multiple channel systems, be sure the number on the probe cable (near the connector) matches the number on the module handle.

The CPL290 provides low and high sensitivity calibrations for a single probe. Use the Sensitivity switch to select the desired sensitivity. Calibration detail is provided on calibration sheets shipped with the product.

Noncontact sensors normally measure changes from a reference position.

Making a basic measurement

1. Connect probe to module
2. Set the target to a reference position or condition
3. Mount probe near target
4. Adjust the probe position until the “Calibrated Range” indicator is at center position
5. Use the Zero adjustments to adjust the output voltage to zero (optional)
6. As the probe/target gap changes, the output voltage will change accordingly

Interpreting the output voltage

The amount of change of the output voltage for a given change in the probe/target gap is called *Sensitivity*. The sensitivity of the sensor is listed on the calibration sheets which arrived with the sensor.

Change in gap calculation:

$$\text{Gap Change} = \text{Voltage Change} / \text{Sensitivity}$$

For example: A sensitivity of 1V/2μm and a voltage change of 3V, the gap change would be 6μm (3/0.5).

Overview of Front Panel Controls, Indicators, and Connectors

Zero Adjust

Adjusts the analog output voltage after the probe is initially positioned. Typically, the analog output voltage is adjusted to zero volts at range center. There is a coarse adjustment, the outer control, and a fine adjustment, the inner control. When the Zero switch is in the off position, the zero adjustment has no effect.

Sensitivity (CPL290 Only)

The CPL290 provides a high-sensitivity and a low-sensitivity calibration for one probe. Refer to the calibration sheets for specific calibration information. Select the desired sensitivity with this switch.

Switching sensitivities will usually require repositioning the probe.

Calibrated Range Indicator

Green LEDs indicate that the probe is in its calibrated range and the output voltage is an accurate representation of the target position. Red LEDs indicate that the probe is out of range and the output voltage is not valid.

The Calibrated Range Indicator is not affected by the Zero adjustment. The module is factory calibrated to zero volts at range center, however, it is possible to adjust the output voltage to zero while the probe is positioned toward the end of the calibrated range. In this situation, the probe can go out of its calibrated range while the output voltage continues to appear valid. The output voltage may continue to change, but the output is no longer guaranteed to be accurate. In this condition, the output voltage may appear valid but the Calibrated Range Indicator will be red. Out-of-Range signals available through the system DAQ connector are activated anytime the Calibrate Range Indicator is red.

Analog Output

Provides connection to the analog output voltage, which is directly proportional to the distance between the probe and the surface of the material being measured. A typical output voltage range is $\pm 10\text{VDC}$. The specific ranges are listed on the accompanying calibration sheets.

The analog output provided on the data acquisition (DAQ) connector on the rear of the enclosure is differential. See the enclosure section of this manual for specifics on the system DAQ connector (page 16).

Ground

A banana-plug cable can be connected here for grounding the target. In most cases, separate grounding of the target is not necessary. If the target is not grounded through another path, and the output exhibits excessive electrical noise, grounding the target may reduce the output noise. When low-noise operation is critical, separate grounding is recommended even if the target is well grounded through another path.

Probe Connector

Connect the probe by aligning the red dots on the connectors and inserting the probe connector.

To disconnect the probe, pull on the knurled barrel of the probe connector to release it.

DO NOT PULL ON THE CABLE.

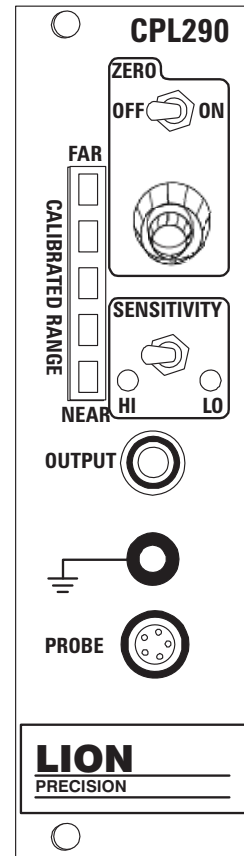

Multiple Channel Measurements

Using multiple sensors on the same target requires that the sensor excitation voltages be synchronized. This is done automatically by the Elite Series enclosures. In addition, even and odd channel numbers use inverted (180°) excitation voltages. This eliminates offset and scale errors that may otherwise occur with poorly grounded targets such as semiconductors. For details on use with ungrounded targets and the advantage of inverted excitation voltages, refer to Lion Precision TechNote *LT03-0022 Capacitive Sensors and Ungrounded Targets*, available at www.lionprecision.com; click on Technical Library.

Bandwidth Settings (Switch S2)

The CPL190/290 provides a two-position dip switch (S2) for setting bandwidth.

When changing bandwidth, change all modules in the system. Bandwidth is a system-wide setting; bandwidth switches on the modules within a system are interconnected. All of the bandwidth switches must be in the same position. Changing only one module in a system may not produce the desired bandwidth.

See *CPL190/290 DIP Switch Access* section for specific mechanical instructions. Be careful to only change switches and jumpers as directed in this manual. Any other changes will affect the calibration of the module.

This dip switch is located as shown in the drawing. The following table shows the bandwidths available and their associated dip switch settings. The bandwidth listed on the accompanying calibration sheets is measured in the 15kHz position. (Computer control of bandwidth requires these switches be in the 15kHz position).

Bandwidths listed are approximate. Actual values depend on the probe and calibration.

	S2-2	S2-1
15kHz*	OFF	OFF
10kHz	OFF	ON
1kHz	ON	OFF
100Hz	ON	ON

*Standard factory configuration

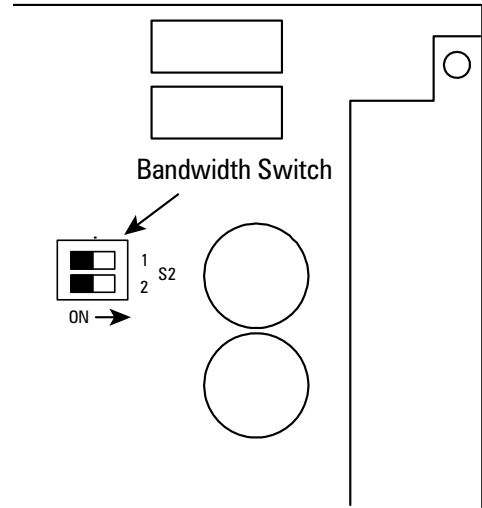

CPL190/290 Specifications¹

Linearity Error	±0.2% Full Scale or better, dependent on calibration
Error Band	±0.3% Full Scale or better, dependent on calibration
Bandwidth	Static to 10kHz ±5% 15 kHz: -3dB Typical
Meets ANSI/ASME B5.54 Standard	Yes
Probe Interchangeability	Typical sensitivity variation for same probe model: 10%
Operating Temperature	4°-66°C 40°-150°F
Thermal Stability	0.02% F.S./°F, 0.04% F.S./°C
Oscillator Frequency	Probe cable < 12 feet: 1MHz Probe cable > 12 feet: 500kHz
Output Impedance	0Ω
Noise Output	6 mV p-p @ 10kHz bandwidth typical

¹ In high EMI environments (10V/m), output noise may rise to 0.2VRMS (1% resolution) and DC output may shift.

Elite Series: MM190 Meter and Function Module

The MM190 Module displays dimensional values derived from sensors within an Elite Series system. Any two channels can be summed and peak capture functions can be performed on an individual channel or a resulting sum. The displayed value is also provided as an analog voltage via a front panel BNC connector.

Capabilities

- Displays dimensional units derived from sensor output voltages
- Selectable input channels
- Sum and Difference of any two channels
- Peak capture functions
- Metric/Inch unit selection
- Analog voltage output proportional to displayed value

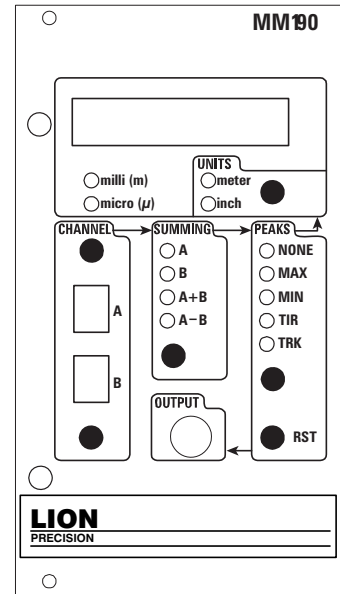

Setup

Pressing the appropriate button repeatedly rotates through selections.

1. Select sensor channels for A and B
2. Select individual channel to be displayed (A or B) or the sum or difference of A and B
3. Select a peak function
4. Select metric or inch units

Display Units

The MM190 measures the analog voltage from the selected sensor channel and uses digital signal processing to perform any summing and/or peak capture functions. The result is converted to actual dimensional units for display. The multiplier indicators (milli, micro) combined with the Metric or Inch units indicate the dimensions of the displayed value. The button selects either Metric or Inch units. The multipliers are not selectable; they are selected by the system based on the calibration values of the displayed channel.

Channel Selection

Any existing sensor channel can be selected for A or B.

Summing Options

A and B can be displayed independently or combined as a sum or a difference.

Peaks

Five options are available:

NONE – Display is real-time value of input channels.

MAX – Displays the most positive value since the Reset (RST) button was pressed.

MIN – Displays the most negative value since the Reset (RST) button was pressed.

TIR – Displays the maximum difference between the MAX and MIN values since the Reset (RST) button was pressed. TIR is always a positive value.

TRK – Tracking TIR displays the *current* maximum difference between the MAX and MIN values. When the TIR value is reduced, the displayed value will decay to the lower value within approximately one second.

Analog Output (BNC)

The analog voltage output from the MM190 BNC connector is scaled the same as the BNC output voltage from the selected sensor channels. For example, if the sensor channels are scaled at 1V/1 μ m, the MM190 will also scaled at 1V/1 μ m.

When two channels are summed, the MM190 BNC output voltage is divided by two. For example, summing sensor channels at 1V/1 μ m each will produce an MM190 output voltage scaled at 0.5V/1 μ m. This allows both sensor channels to operate at full ± 10 V without exceeding the ± 10 V of the MM190.

MM190 Specifications

BNC Output Scaling Error:	-3.0%
Internal Scaling Error:	0.2%
Difference Error:	0.2%
Summing Error:	0.2%
Tracking TIR Error Relative to Frequency: (not recommended below 100Hz)	10Hz: -15.0% 100Hz: $\pm 0.3\%$ 1kHz: $\pm 1.5\%$ 5kHz: $\pm 4.0\%$
TIR Error Relative to Input Frequency:	DC: -15.0% 1kHz: $\pm 1.3\%$ 5kHz: $\pm 4.0\%$
Peak Droop:	1mV/15 seconds
BNC Output Impedance	150 Ohms

Elite Series: TMP190 Temperature Sensing and Encoder/Index Input Module

The TMP190 Module monitors up to seven channels of temperature data and provides signal conditioning and input connections for encoder and index inputs.

Requirements

The TMP190 is primarily used with the Lion Precision Spindle Error Analyzer. For use without the Spindle Error Analyzer, National Instruments Virtual Instruments drivers are available online at: www.lionprecision.com/vi.

Operation – Temperature Sensing

Temperature Probes

Thermistor type temperature probes are used with the TMP190 which supports up to seven channels of temperature sensing.

Temperature probes provided with the module use YSI thermistors:
YSI 44036 Series Thermistor (10kW @ 25° C).

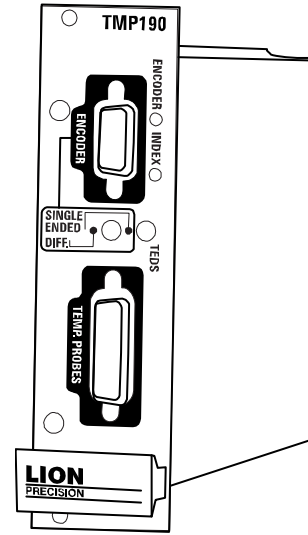

Temperature Probe	
Magnetic Surface Probe. P016-4050	

Making Temperature Measurements

Place temperature probes in positions to take desired measurements. When measuring surface temperatures, solid mechanical contact is important.

Use Spindle Error Analyzer (SEA) Software or Virtual Instrument Driver to extract temperature readings.

Block Diagram - Temperature

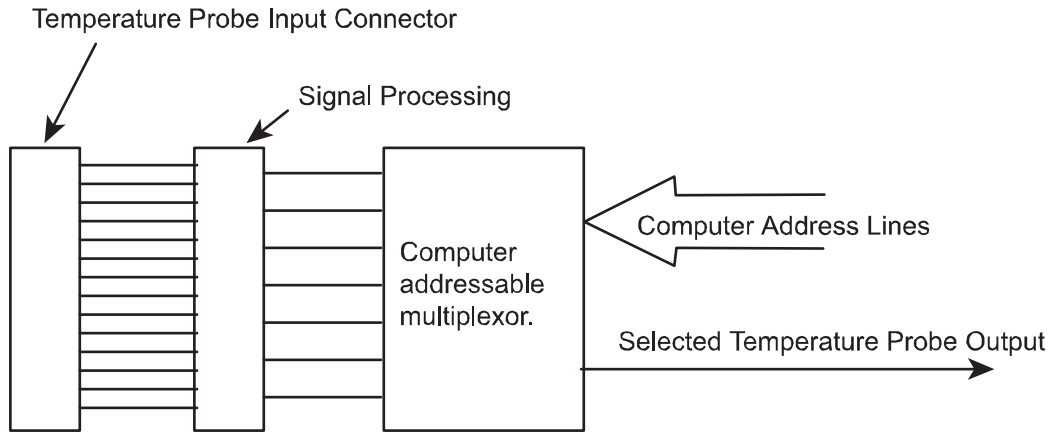

Connections to Temperature Probes

The two wires of each temperature probe are connected according to the chart below. The probes are by nature unpolarized so there is no differentiation between the two conductors.

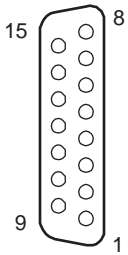

Pin Numbers	Connection	Pin Numbers	Connection
1, 9	Probe 1 (T1)	5, 13	Probe 5 (T5)
2, 10	Probe 2 (T2)	6, 14	Probe 6 (T6)
3, 11	Probe 3 (T3)	7, 15	Probe 7 (T7)
4, 12	Probe 4 (T4)	8	No connection

Specifications¹

Accuracy	$\pm 1.8^{\circ}\text{F}@40^{\circ}\text{F} - 180^{\circ}\text{F}$	$\pm 1.0^{\circ}\text{C}@4^{\circ}\text{C} - 82^{\circ}\text{C}$
Output Voltage	$\pm 10\text{VDC}$	
Measuring Range	$40^{\circ}\text{F} - 180^{\circ}\text{F}$	$4^{\circ}\text{C} - 82^{\circ}\text{C}$
Temperature Probe Interchangeability Error	$\pm 0.2^{\circ}\text{F} @ 68^{\circ}\text{F}$	$\pm 0.1^{\circ}\text{C} @ 20^{\circ}\text{C}$

¹Shifts as high as 4°C may occur in high EMI conditions (10V/m).

Encoder/Index Pulse Input

The TMP190 also processes encoder and index pulse inputs for use by the Spindle Error Analyzer. The module performs basic signal processing on the incoming signal then passes the conditioned signal to the data acquisition hardware for analysis by the software.

By definition, index pulses occur once during each rotation of the spindle. Encoder pulses occur many times per revolution. Both are used to provide angular location information to software during a measurement of a rotating target.

Encoder and Index LEDs

To help verify encoder and index pulse operation, green LEDs indicate activity on the encoder and index inputs by flashing at half the frequency of the corresponding input signal.

Single-Ended or Differential Inputs

Encoder and index inputs can be configured as single-ended or differential.

In single-ended mode, the signal is measured between the + input and ground. In differential mode, the signal is measured between the + and – inputs.

Differential inputs are less susceptible to noise and interference. Noise and interference from the measurement environment is often injected equally into both wires from the encoder or index generator. When the signal is taken differentially, the noise and interference is canceled resulting in a cleaner signal.

The front panel switch selects the operating mode.

Connections – Encoder/Index

DC power is available on the connector to power encoders or proximity switches.

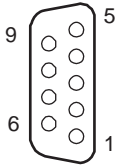

Pin Number	Signal
1	Ground
2	Ground
3	+5VDC, 200mA max. with self-resetting fuse
4	Ground
5	+15VDC, 100mA max. with self-resetting fuse
6	– Index input, ±12V Max.
7	+ Index input, ±12V Max.
8	– Encoder input, ±12V Max.
9	+ Encoder input, ±12V Max.

Block Diagram – Encoder/Index

Differential Input Configuration

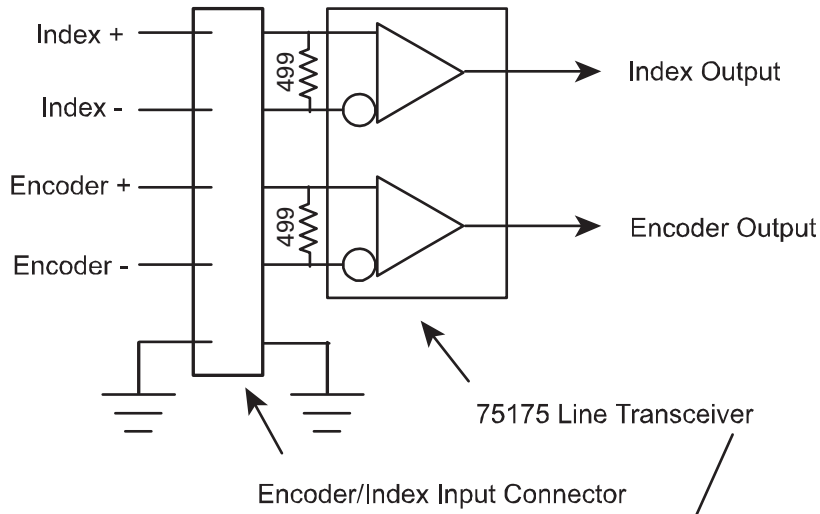

Single-Ended Input Configuration

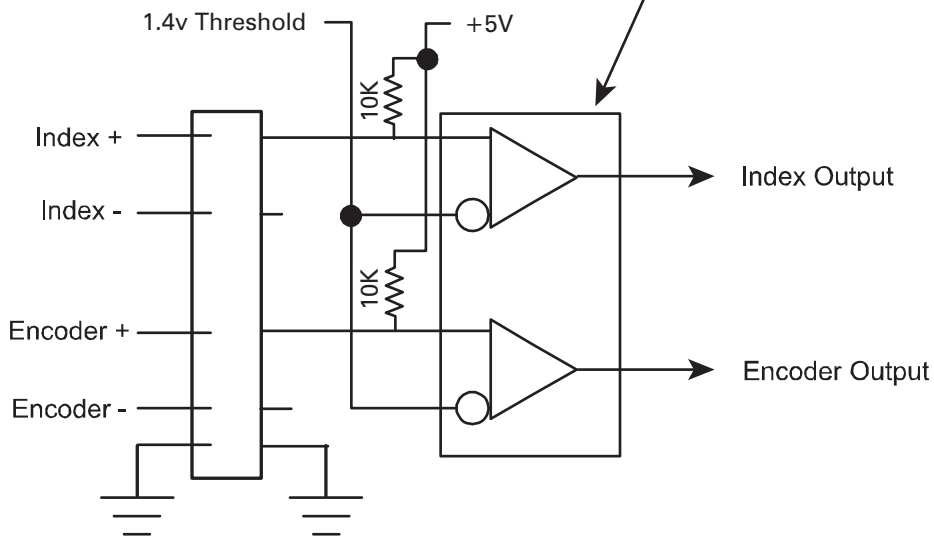

Detailed datasheet on the 75175 Transceiver is available at:
<http://focus.ti.com/lit/ds/symlink/sn75175.pdf>

TEDS (Transducer Electronic Data Sheet)

TEDS (Transducer Electronic Data Sheet) provides calibration information electronically to the Spindle Error Analyzer system or any system using the Virtual Instrument drivers. The TMP190 TEDS communicates the serial number and calibration information for the TMP190 module.

TEDS Front Panel Connector

A TEDS connector on the front panel of the TMP190 receives the TEDS module associated with the Spindle Error Analyzer Master Ball Targets. When the TEDS module is plugged in, the Spindle Error Analyzer software uses the target calibration and roundness information to adjust measurements to maximum accuracy and record the target roundness specifications in files and reports.

Elite Series Enclosures

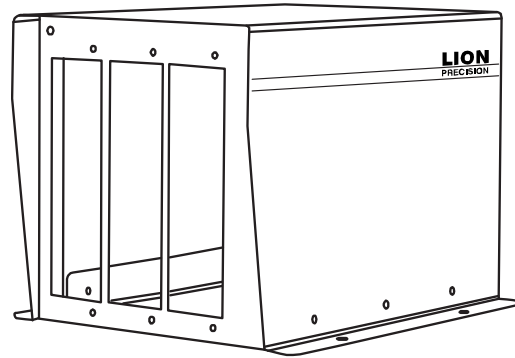
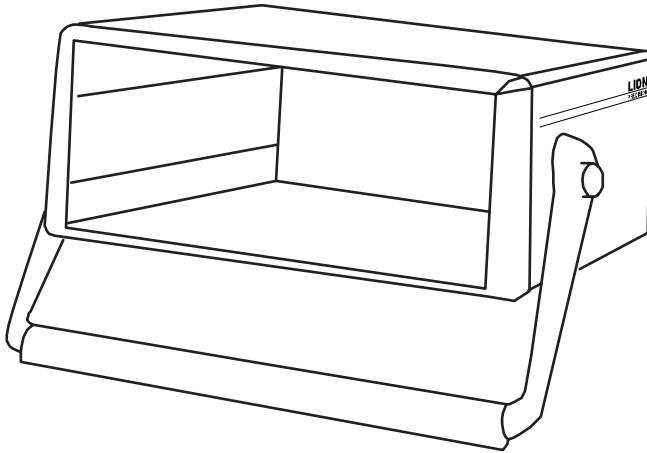

Elite Series enclosures provide housing and critical signals to Elite Series modules. Sensor output signals are available via a rear-panel high-density connector which is configured for direct connection to National Instruments™ data acquisition hardware. A LabView virtual instrument driver is available at www.lionprecision.com/vi.

The specific Elite Series enclosure model number indicates the maximum number of slots available for plug-in modules as well as other features:

Model	Number of module slots	Input power	Tip-up handle	Mounting flanges
EN191	1	±15VDC	No	Yes
EN192	2	±15VDC	No	Yes
EN193	3	±15VDC	No	Yes
EN196	6	100-250VAC 50/60 Hz	Yes	No
EN198	8	100-250VAC 50/60 Hz	Yes	No

Power Specifications

Model	Power Input	Notes
EN191, EN192, EN193	±15VDC ±5%, 400mA Maximum (A power supply is included with orders)	To maintain maximum resolution use a linear power supply or a power supply with switching frequency greater than 100kHz such as Lion Precision Power Supply P014-5040. To maintain CE compliance, use the included power supply or equivalent CE compliant model.
EN196, EN198	100-250VAC, 50/60Hz, 250VA Maximum	

EN191, EN192, EN193 Power Connector

Pin	Connection
1	Ground
3	-15VDC
4	+15VDC

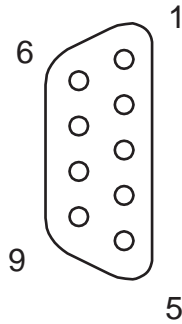

Power Connector
Pin Numbers
On Rear Panel

External Power Supply

EN191, EN192, and EN193 systems include an external power supply. The supply has a connector which allows direct connection to the enclosure.

This supply features a high-frequency (100kHz) switching supply. The high switching frequency allows the sensing modules to operate at maximum resolution.

DC Output Voltage	+15VDC; 2.0A -15VDC; 1.0A
AC Input Voltage	100-240VAC, 50/60Hz, 1.35A max

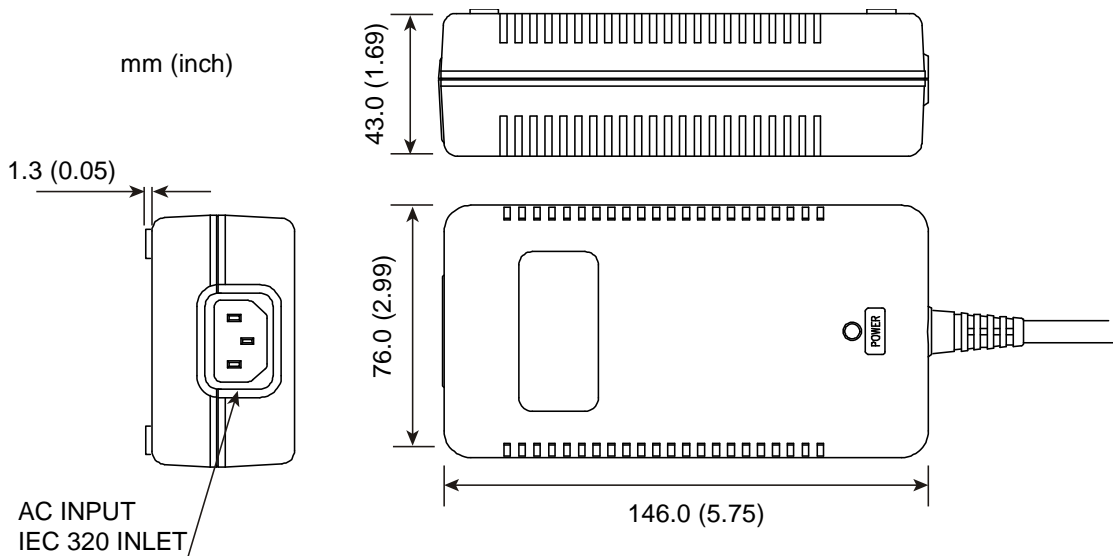

DAQ Connector Pinout

All unlisted pins are reserved for proprietary use by Lion Precision and should not be connected to external contacts.

Pin	Output Signals
11	Encoder
12, 13, 15, 18, 53	Digital Ground
29, 32, 64, 67	Analog Ground
23	- Analog Out; Channel 8
25	+ Analog Out; Channel 7
26	- Analog Out; Channel 6
28	+ Analog Out; Channel 5
30	+ Analog Out; Channel 4
31	- Analog Out; Channel 3
33	+ Analog Out; Channel 2
34	- Analog Out; Channel 1
57	+ Analog Out; Channel 8
58	- Analog Out; Channel 7
60	+ Analog Out; Channel 6
61	- Analog Out; Channel 5
63	- Analog Out; Channel 4
65	+ Analog Out; Channel 3
66	- Analog Out; Channel 2
68	+ Analog Out; Channel 1

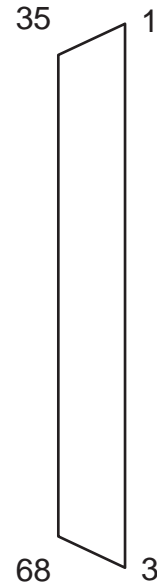

DAQ Connector
Pin Numbers

Mechanical Specifications: EN191, EN192, EN193

Model	A	B	C
EN191	3.33" 84.6mm	2.606" 66.2mm	3.806" 96.7mm
EN192	4.73" 120.1mm	4.006" 101.8mm	5.206" 132.2mm
EN193	6.13" 155.7mm	5.406" 137.3mm	6.606" 167.8mm

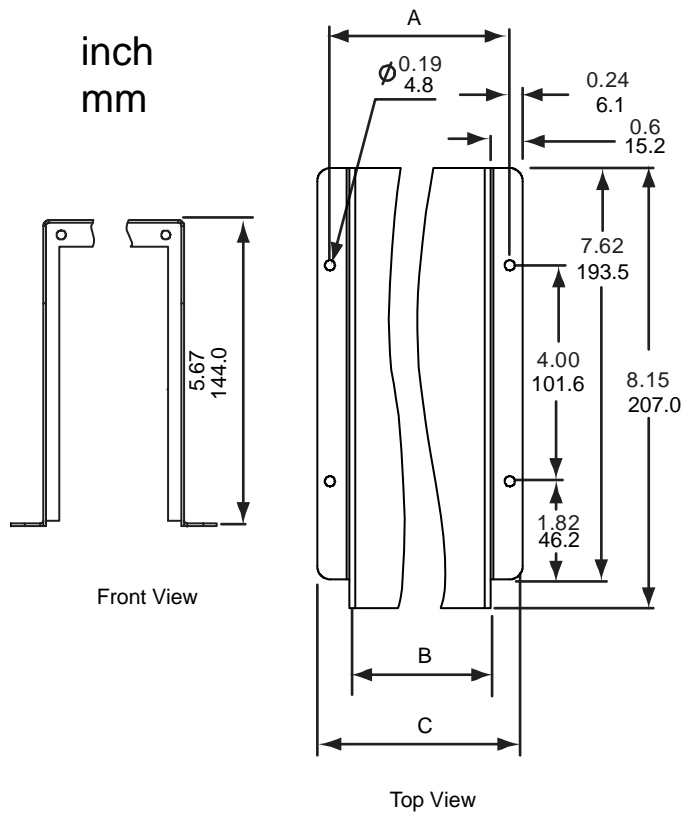

Mechanical Specifications: EN196, EN198

Model	A
EN196	10.2" 259.1mm
EN198	14.6" 370.8mm

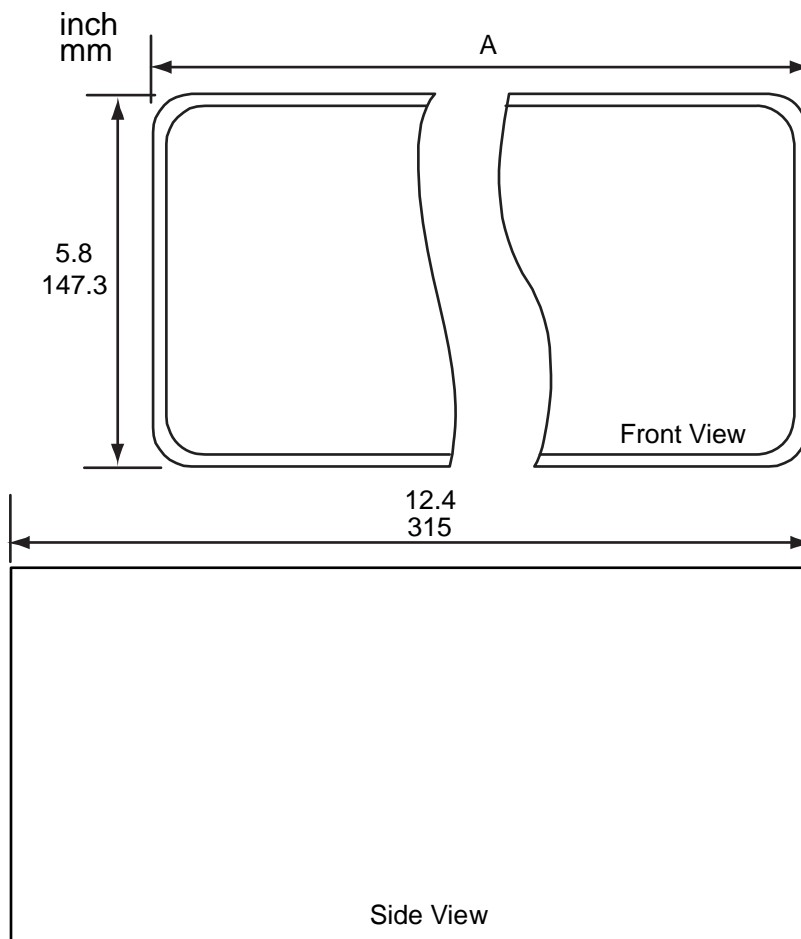

CPL190/290 DIP Switch Access

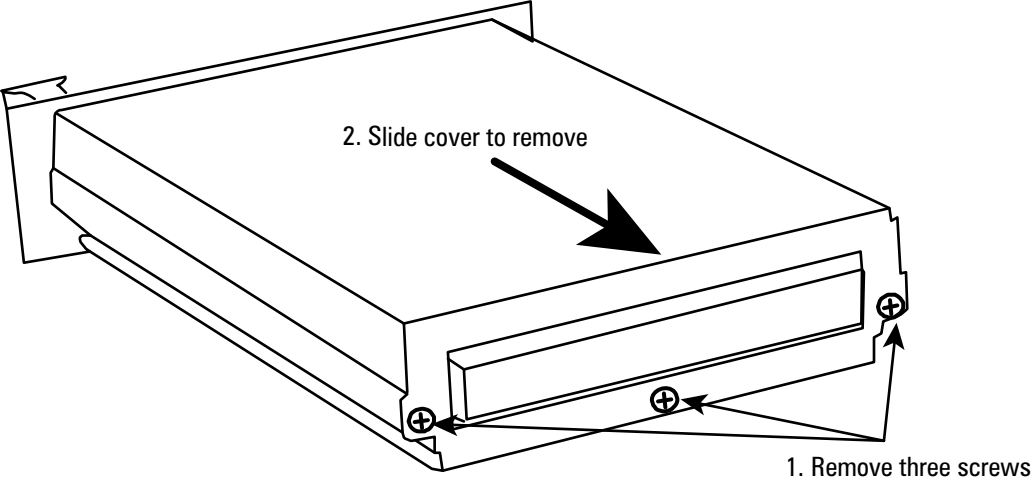

Accessories

Air-Bearing C-LVDT: Capacitive LVDT-Type Contact Sensor

The Air-Bearing C-LVDT converts a capacitive sensor into to high-precision contact displacement sensor similar to an LVDT. The capacitive sensor is installed in the top of the C-LVDT body where it measures the location of a target connected on the inside end of the stylus. The C-LVDT uses a linear air-bearing for nearly friction-free movement of the stylus, and the porous carbon air bearing is square to prevent stylus rotation. Adjustable air pressure for extending the stylus provides for contact forces less than one gram, and the C-LVDT features a retraction port through which application of air pressure will retract the stylus.

The C-LVDT uses an interchangeable diamond tip. Diamond has been selected over ruby for the following reasons:

- Low Friction - Side forces cause less lateral deflection from moving targets and less hysteresis on direction reversal.
- Highly Polished Surface - Diamond accepts and holds a high polish, minimizing the possibility of scratching the measured surface.
- Minimal Wear - Increased accuracy and longer life.

Contact Force Adjustment

There is a contact force adjustment screw located on the end of the probe body near the cable exit. Use a 1/16" hex key to turn the adjustment clockwise to increase the contact force or counter clockwise to decrease it. Contact force is also a function of the air pressure applied to the C-LVDT. To maintain constant contact force, supplied air pressure must be held constant.

Air Exhaust

The 0.1" slot around the body near the top of the C-LVDT is where air is exhausted. Do not clamp the C-LVDT over this ring. The ring must remain at least partially clear at all times for proper operation of the C-LVDT.

Specifications

Measurement Range	0.5mm, 0.020"
Contact Force	0.2g to 100g
Radial Stiffness	< 0.25 μ m/g
Bearing	Linear, porous air bearing
Diamond Tip	Radius: 3.175mm, 0.125" Mount: 4-48AGD Thread
Weight of Moving Mass	4.2g
Air Connection	1/16" ID flexible tubing
Air Consumption	3-7 lpm, 0.10-0.25 cfm
Operating Air Pressure	420-480kPa, 60-70psi
Air Filter Requirement	5 μ m particle size

Mechanical Detail

